

3.8m Offset Antenna System Assembly Manual

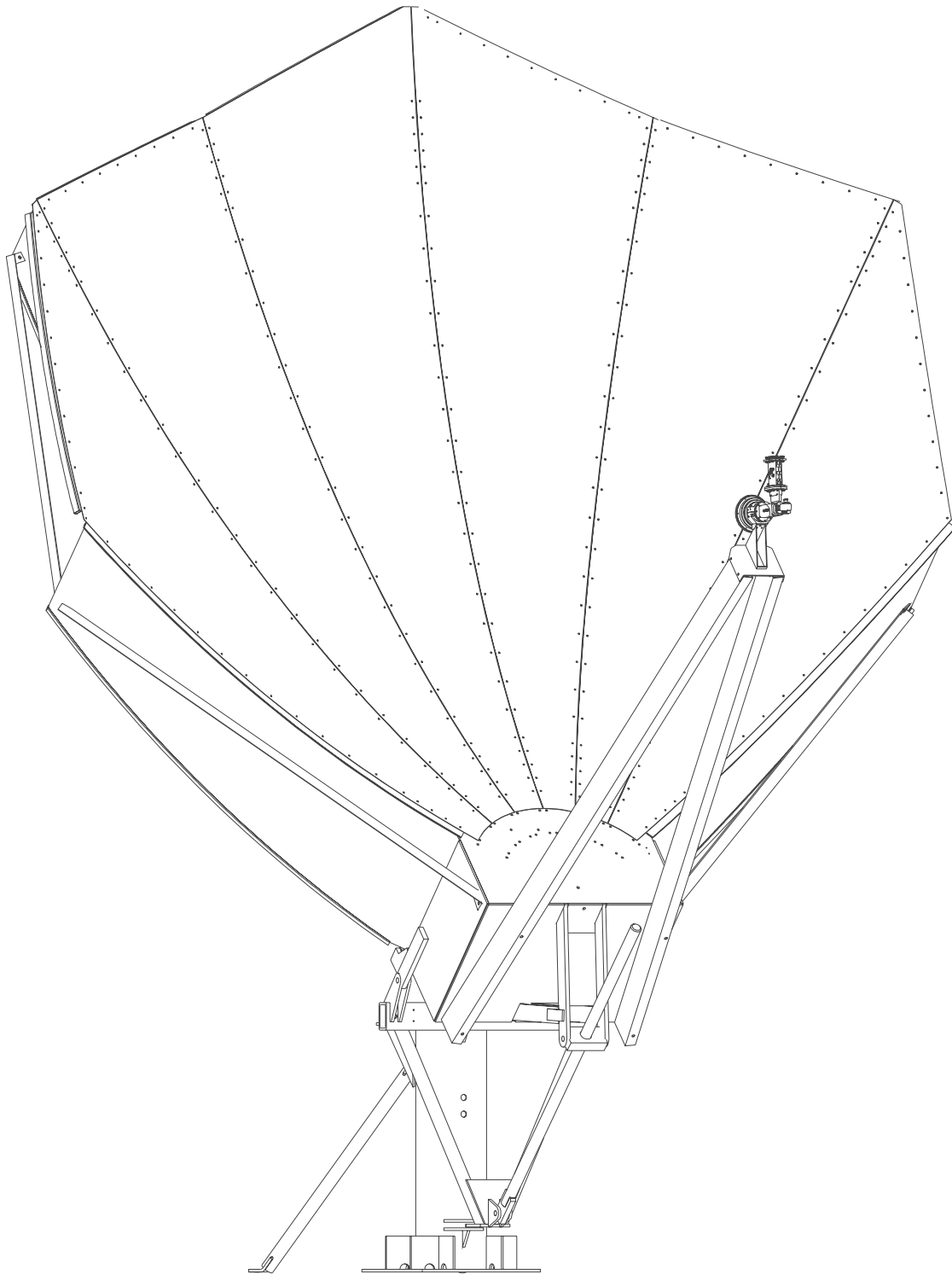



LIMITED TWELVE (12) MONTH WARRANTY

This CHALLENGER COMMUNICATIONS, LLC ("CHALLENGER") equipment is warranted to be free from defects in material and workmanship under normal use and service. CHALLENGER shall repair or replace defective equipment, at no charge, or at its option, refund the purchase price, if the equipment is returned to CHALLENGER not more than twelve (12) months after shipment. Removal or reinstallation of equipment and its transportation shall not be at cost of CHALLENGER except CHALLENGER shall return repaired or replaced equipment freight prepaid.

This Warranty shall not apply to equipment which has been repaired or altered in any way so as to affect its stability or durability, or which has been subject to misuse, negligence or accident. This Warranty does not cover equipment which has been impaired by severe weather conditions such as excessive wind, ice, storms, lightning, or other natural occurrences over which CHALLENGER has no control, and this Warranty shall not apply to equipment which has been operated or installed other than in accordance with the instructions furnished by CHALLENGER.

Claimants under this Warranty shall present their claims along with the defective equipment to CHALLENGER immediately upon failure. Noncompliance with any part of this claim procedure may invalidate this warranty in whole or in part.

THIS WARRANTY IS EXPRESSLY IN LIEU OF ALL OTHER AGREEMENTS AND WARRANTIES, ANY IMPLIED WARRANTY OF MERCHANTABILITY OR FITNESS FOR A PARTICULAR PURPOSE IS LIMITED IN DURATION TO THE DURATION OF THIS WARRANTY. CHALLENGER DOES NOT AUTHORIZE ANY PERSON TO ASSUME FOR IT THE OBLIGATIONS CONTAINED IN THIS WARRANTY AND CHALLENGER COMMUNICATIONS NEITHER ASSUMES NOR AUTHORIZES ANY REPRESENTATIVE OR OTHER PERSON TO ASSUME FOR IT ANY OTHER LIABILITY IN CONNECTION WITH THE EQUIPMENT DELIVERED OR PROVIDED.

IN NO EVENT SHALL CHALLENGER BE LIABLE FOR ANY LOSS OF PROFITS, LOSS OF USE, INTERRUPTION OF BUSINESS, OR INDIRECT, SPECIAL OR CONSEQUENTIAL DAMAGES OF ANY KIND.

In no event shall CHALLENGER be liable for damages in an amount greater than the purchase price of the equipment.

Some states do not allow limitations on how long an implied warranty lasts, or allow the exclusion or limitation of incidental or consequential damages, so the above limitations or exclusions may not apply to you.

CHALLENGER has the right to void the warranty when the antenna is installed by someone other than a certified installer.

Product Serial Number: _____

Date Purchased: _____

Challenger Communications

704 North Clark Street

Albion, Michigan 49224 USA

Tel: (01) 517 680 0125

Fax: (01) 517 680 0133

info@challengercommunications.com

www.ChallengerCommunications.com

IMPORTANT!

INSTALLATION OF THIS PRODUCT SHOULD BE PERFORMED ONLY BY A PROFESSIONAL INSTALLER AND IS NOT RECOMMENDED FOR CONSUMER D.I.Y. (DO-IT-YOURSELF) INSTALLATIONS.

WATCH FOR WIRES

Installation of this product near power lines is dangerous. For your own safety, follow these important safety rules:

1. Perform as many functions as possible on the ground.
2. Watch out for overhead power lines. Check the distance to the power lines before starting installation.
3. Do not use metal ladders.
4. Do not install antenna or mast assembly on a windy day.
5. If you start to drop antenna mast assembly, get away from it and let it fall.
6. If any part of the antenna or mast assembly comes in contact with a power line, call your local power company. **DO NOT TRY TO REMOVE IT YOURSELF!** They will remove it safely.
7. Make sure that the mast assembly is properly grounded.

WARNING

Assembling dish antennas on windy days can be dangerous. Because of the antenna surface, even slight winds create strong forces. For example, a 1.0m antenna facing a wind of 32 km/h (20 mph) can undergo forces of 269 N (60 lbs.). Be prepared to safely handle these forces at unexpected moments. Do not attempt to assemble, move or mount dish on windy days or serious, even fatal accidents may occur. Challenger Communications is not responsible or liable for damage or injury resulting from antenna installations.

RECOMMENDATION

CHALLENGER COMMUNICATIONS highly recommends the application of anti-seize wax on all antenna and mount hardware upon installation.

Item	Part Description	Part Number	Quantity
1	3.8m Offset, Panel "A" Left	380-0017	1
2	3.8m Offset, Panel "A" Right	380-0016	1
3	3.8m Offset, Panel "B"	380-0018	2
4	3.8m Offset, Panel "C" Left	380-0020	1
5	3.8m Offset, Panel "C" Right	380-0019	1
6	3.8m Offset, Assy, Radial Beam "A"	380-A001	1
7	3.8m Offset, Assy, Radial Beam "B"	380-A002	2
8	3.8m Offset, Assy, Radial Beam "C"	380-A003	2
9	3.8m Offset, Assy, Back Support	380-A005	2
10	3.8m Offset, Assy, Kerfing "B" 42.68"	380-A009	2
11	3.8m Offset, Assy, Kerfing "A" 46.79"	380-A010	2
12	3.8m Offset, Assy, Kerfing "C" 57.00"	380-A011	2
13	3.8m Offset, Feed Boom	380-0025	2
14	3.8m Offset, Feed Pallet Weldment	380-A004	1
15	3.8m Offset, Kingpost/Yoke Assembly	380-KPY	1
16	3.8m Offset, Kingpost Mast Strut Assy	380-MAST	2
17	3.8m Offset, Hub Assembly	380-H	1
18	3.8m Offset, Elevation Rod Assy	380-A008	1
Page 6	3.8/4.5m, King Post Base Reinforcement	45K-0013	4
Page 7	3.8m Offset, Az Lockdown Bottom Plate	380-0031	1
Page 7	3.8m Offset, Az Lockdown Top Plate	380-A006	1
Page 7	3.8m Offset, Azimuth Threaded Rod Assy	380-A007	1
Page 9	3.8m Offset, Feed Boom Shim	380-0052	12
Page 10	3.8m Offset, Radial Beam Angle	380-0015	28
Page 11	3.8m Offset, 65" Back Support L		1
Page 11	3.8m Offset, 65" Back Support R		1
Page 11	3.8m Offset, Radial Tie-Down Bracket	380-0042	21
Page 11	3.8m Offset, 45" Radial Tie-Down	380-0041	4
Page 11	3.8m Offset, 32" Radial Tie-Down	380-0040	6
	Master Hardware Kit	3HP38011	1

Tools Needed

- 1- 5/32", 3/16" , 1/4" allen wrenches
- 2- Combination wrenches -
7/16", 1/2", 9/16", 3/4", 15/16", 1-1/8"
- 1- Large Crescent wrench or Pipe Wrench with
3in. jaw opening
- 1- Inclinator (for sighting in)
- 1- Compass (for sighting in)

- 1- Impact drill
(for drilling cement anchor holes)

Preinstallation materials checklist

- Grounding Rod Clamp & Grounding Block - As required by
National Electric Code or local codes.
- Ground Wire - #10 solid copper or as required by National
Electric Code or local codes.
- Coaxial Cable (Size & Length required).
- Concrete & Rebar (See Foundation Appendix A).

Reference Drawing

Refer to Parts and Hardware list on page 4 for part descriptions. This figure is an overall assembled antenna and can assist the installer with locating parts and understanding the relationship between components.

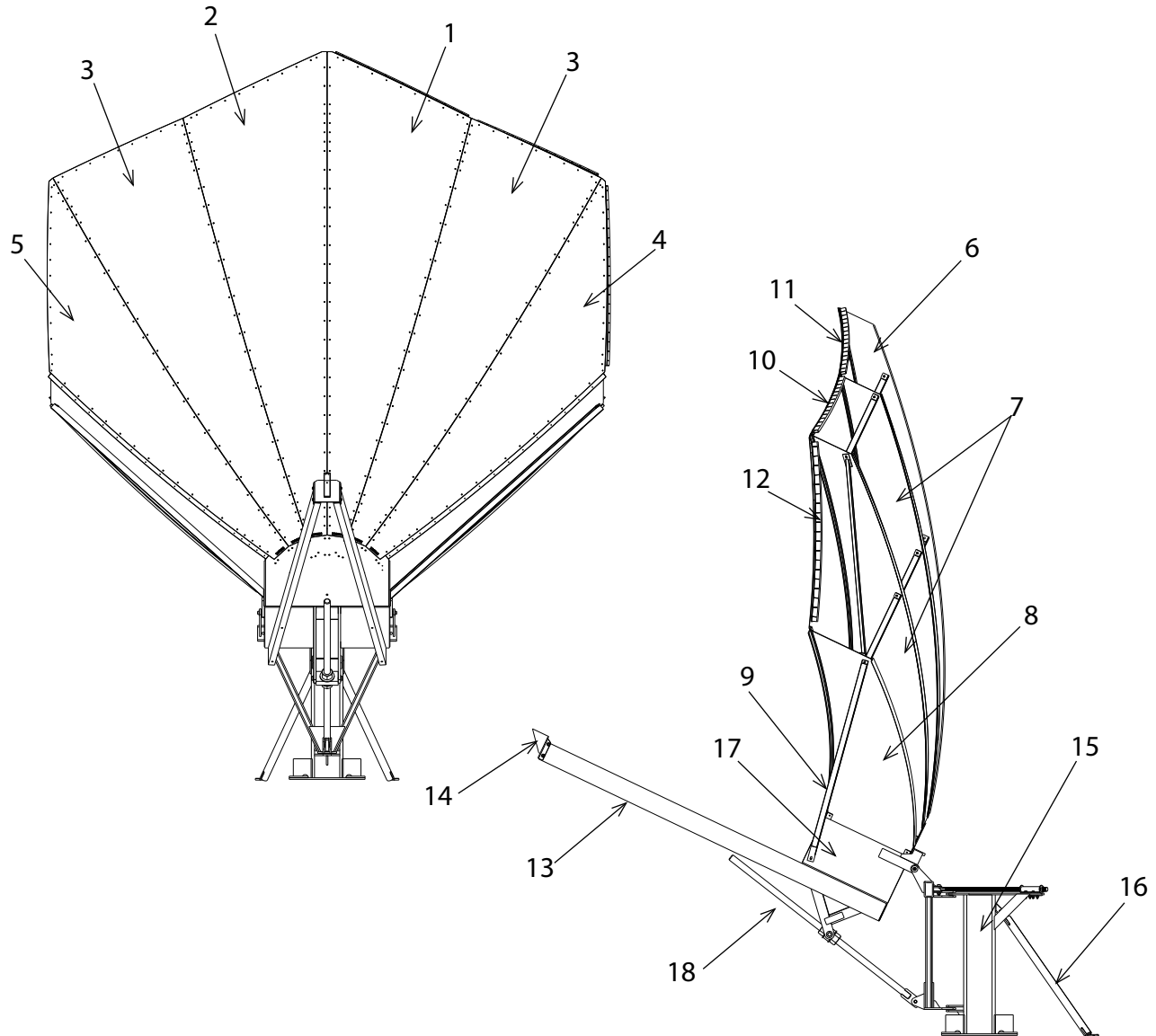

King Post Assembly Placement

1. Place the King Post Mast assembly onto the foundation threaded rods and secure with nuts and washers from the foundation hardware pack. Be sure to use the 4-base reinforcement plates provided as shown. NOTE: The mast should be pointed due south (northern hemisphere sites).

2. Attach ASSY, 3.8M OFFSET MAST STRUT (380-MAST) using 5/8" hardware. Mark area on foundation for cement anchor placement. (See page 16 for foundation details and anchor requirements.) NOTE: The use of an impact drill for drilling cement will be needed.

3. Assemble either the Fixed or Motorized Mount Assembly Kit option purchased with the system.

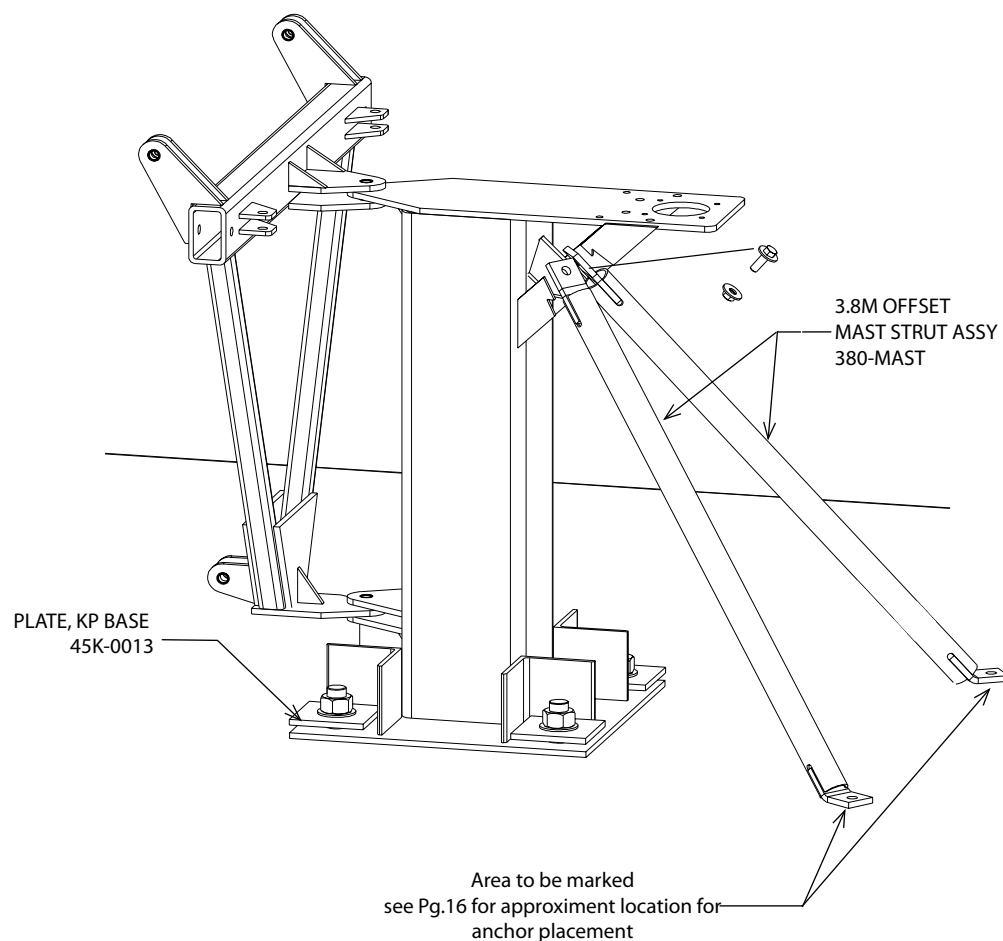

Az Lockdown Assembly

1. Attach 3.8m OFFSET AZ LOCK DOWN TOP PLATE (380-A006) and 3.8 OFFSET LOCK DOWN BOTTOM PLATE (380-0031) to Kingpost assembly using (4) 1/2nc x 2-1/4" bolts and matching washers. Leave hardware loose at this time.
2. Slide AZ THREADED ROD ASSY (380-A007) through tube on lock down plate as pictured below. Leave hardware loose at this time.
3. Attach yoke end of AZ THREADED ROD ASSY to yoke using 3/4" x 2.00" shoulder bolt and 5/8" washers as pictured below.
4. Tighten all hardware once proper AZ angle has been set.

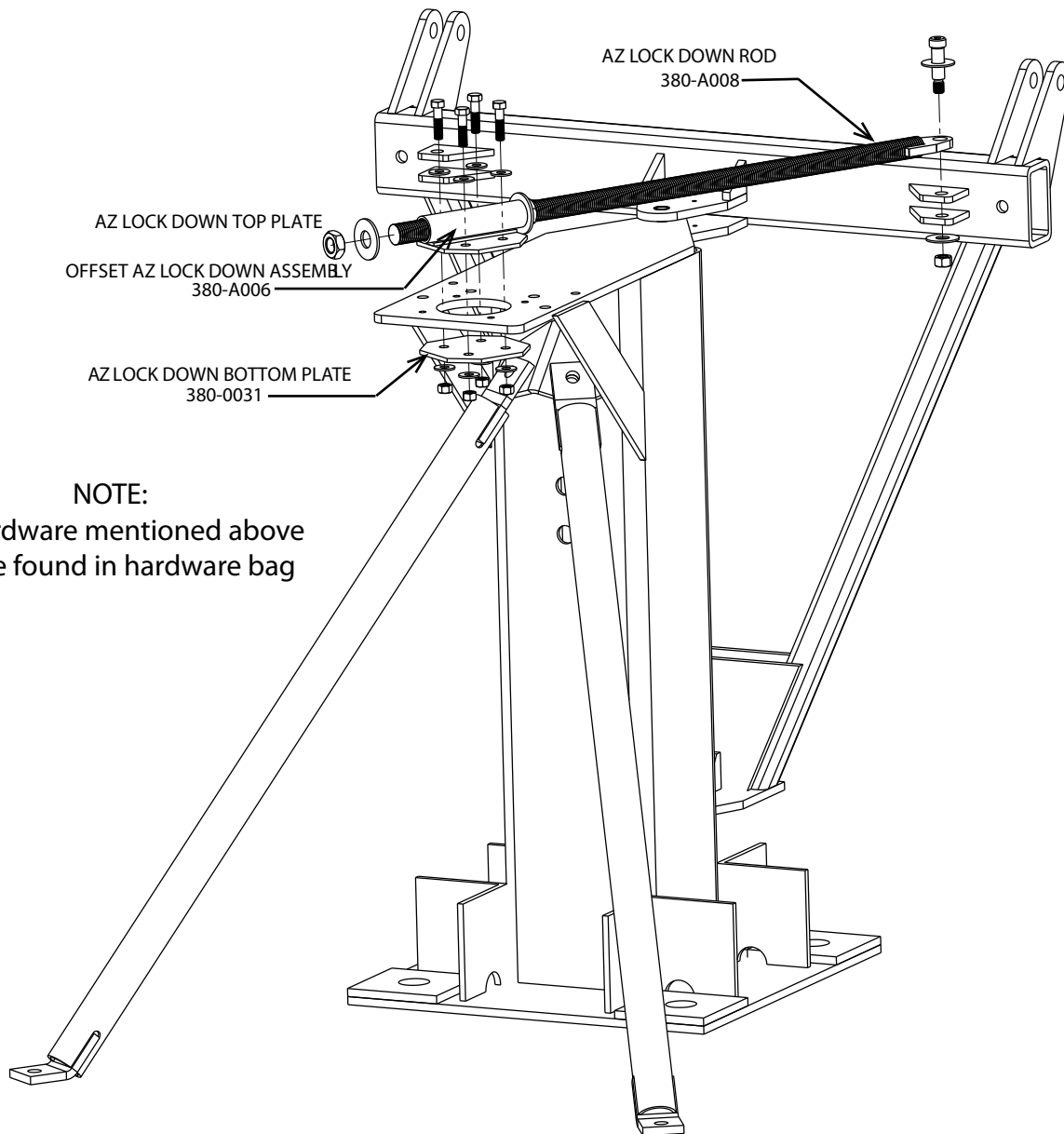

Hub Assembly

1. Attach 3.8m OFFSET, EL ROD ASSY (380-A008) to yoke pick up detail using 3/4" x 2.00" shoulder bolt, 5/8" nut and washer.
2. Place 3.8m OFFSET KP ELEV. PIVOT BLOCK (380-0035) on to 3.8m OFFSET, EL ROD ASSY as pictured below. Leave THIS hardware loose at this time.
3. Place the HUB ASSEMBLY (380-H) on to the A-frame using the pre-installed shoulder bolt hardware as shown.
4. Attach 3.8 OFFSET KP ELEV.PIVOT BLOCK (380-0035) to HUB ASSEMBLY using (2) 3/4nc x 1-1/2" bolts and matching lock washers.
5. Tighten all hardware at this time.

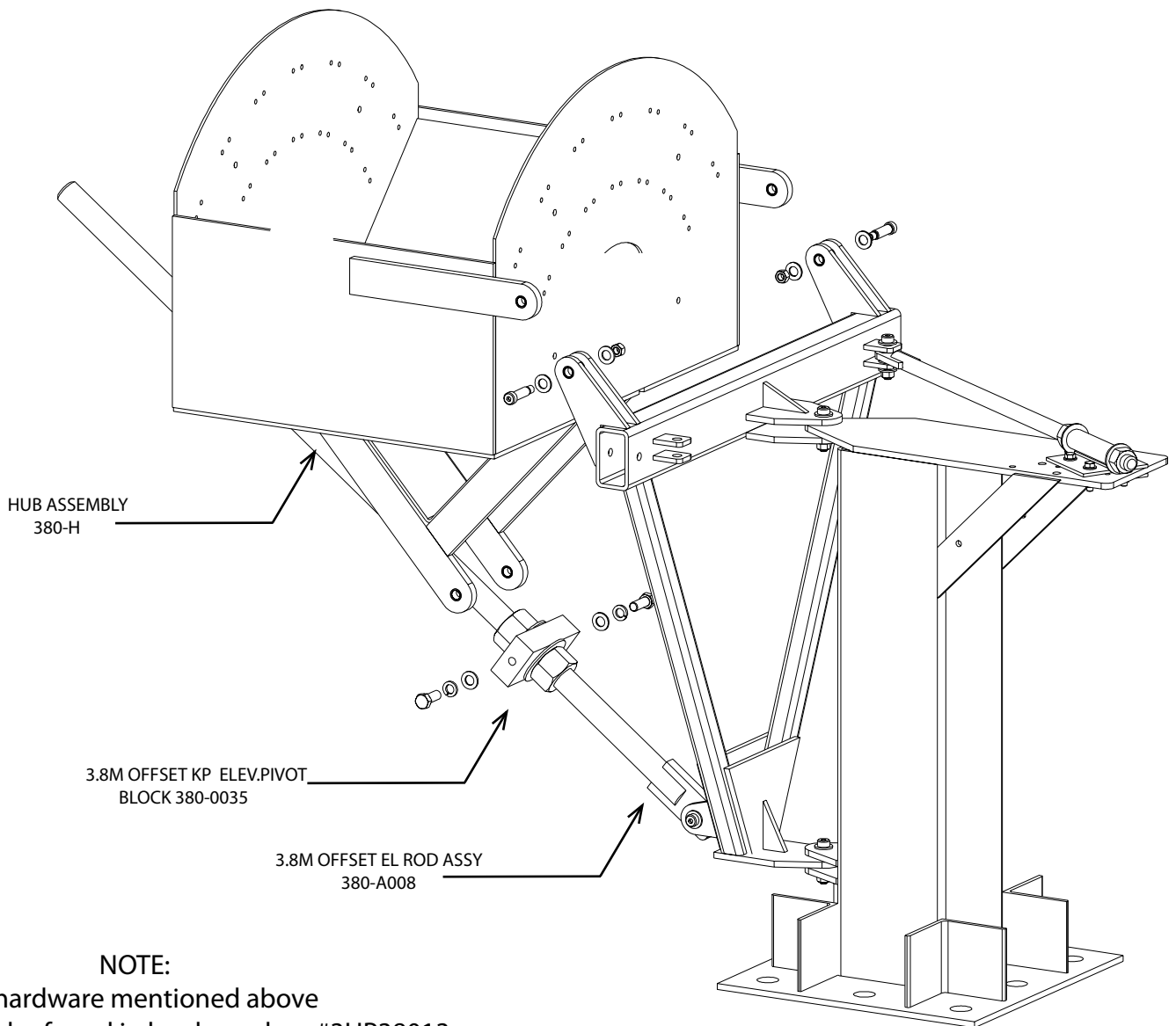

Feed Boom Install

1. Install OFFSET, FEED BOOM (380-0025) using (4) 1/2nc x 7.00" bolts, matching washers and (4) FEED BOOM SHIMS (380-0052).

2. Tighten all Feed Support hardware.

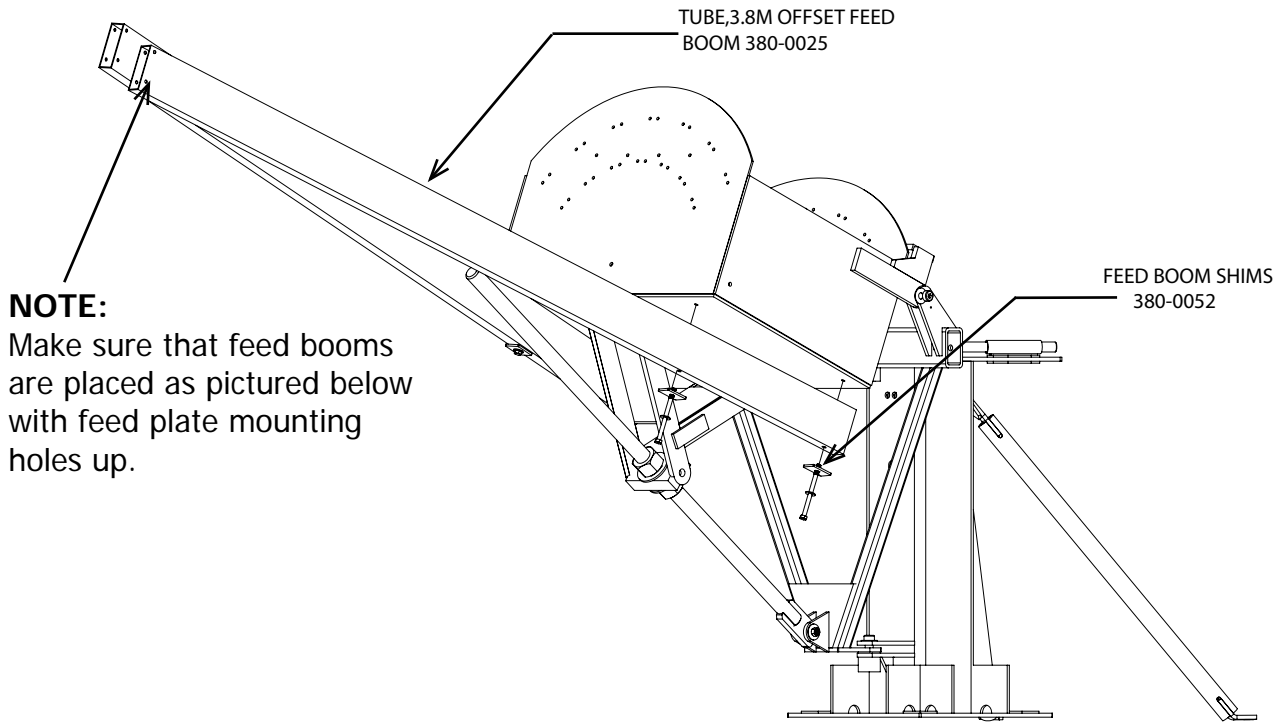

NOTE:
Make sure that feed booms are placed as pictured below with feed plate mounting holes up.

Feed Plate Assembly Install

1. Install 3.8M OFFSET FEED PALLET WELDMENT (380-A004) using (4) 3/8nc x 3.00" bolts, washers and nuts.

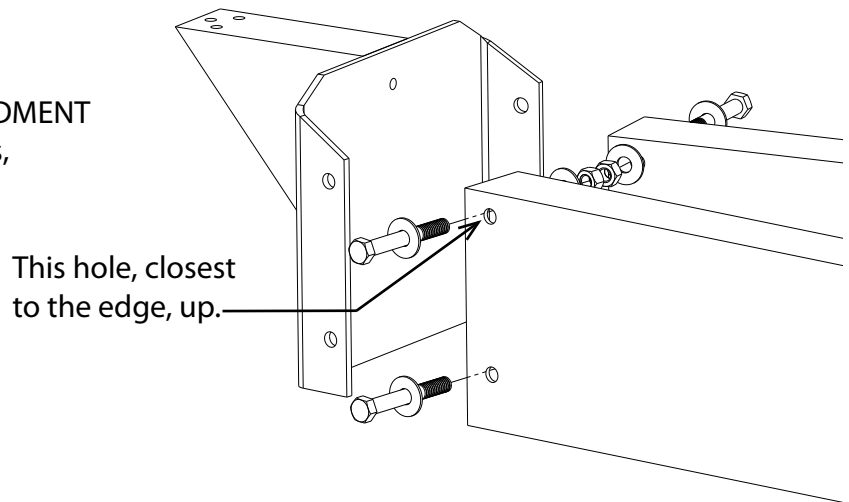

NOTE:
All hardware mentioned above can be found in hardware bag #3HP38016.

Radial Beam Install

1. Fasten (4) RADIAL BEAM ANGLE (380-0015) to each Radial Beam as shown, using (4) 3/8" shoulder (1) 5/16" washer, and nut per.
2. Adjust the Hub into the position shown, and select 3.8M OFFSET RADIAL BEAM C ASSEMBLY (380-A003), and place into the outermost location inside the Hub. Fasten using 3/8in shoulder bolt hardware, (1) 5/16" washer, nut per, keep loose. Do the same with the opposing 3.8M OFFSET RADIAL BEAM C ASSEMBLY (380-A003).

NOTE: Hard to reach hardware can be accessed by reaching inside and around the end of the Radial Beam to reach the back side.

3. Repeat step 2 for 3.8M OFFSET RADIAL BEAM B ASSEMBLY (380-A002) 3.8M OFFSET RADIAL BEAM A ASSEMBLY (380-A001).
4. Tighten all Radial Beam hardware in steps 1 through 3.

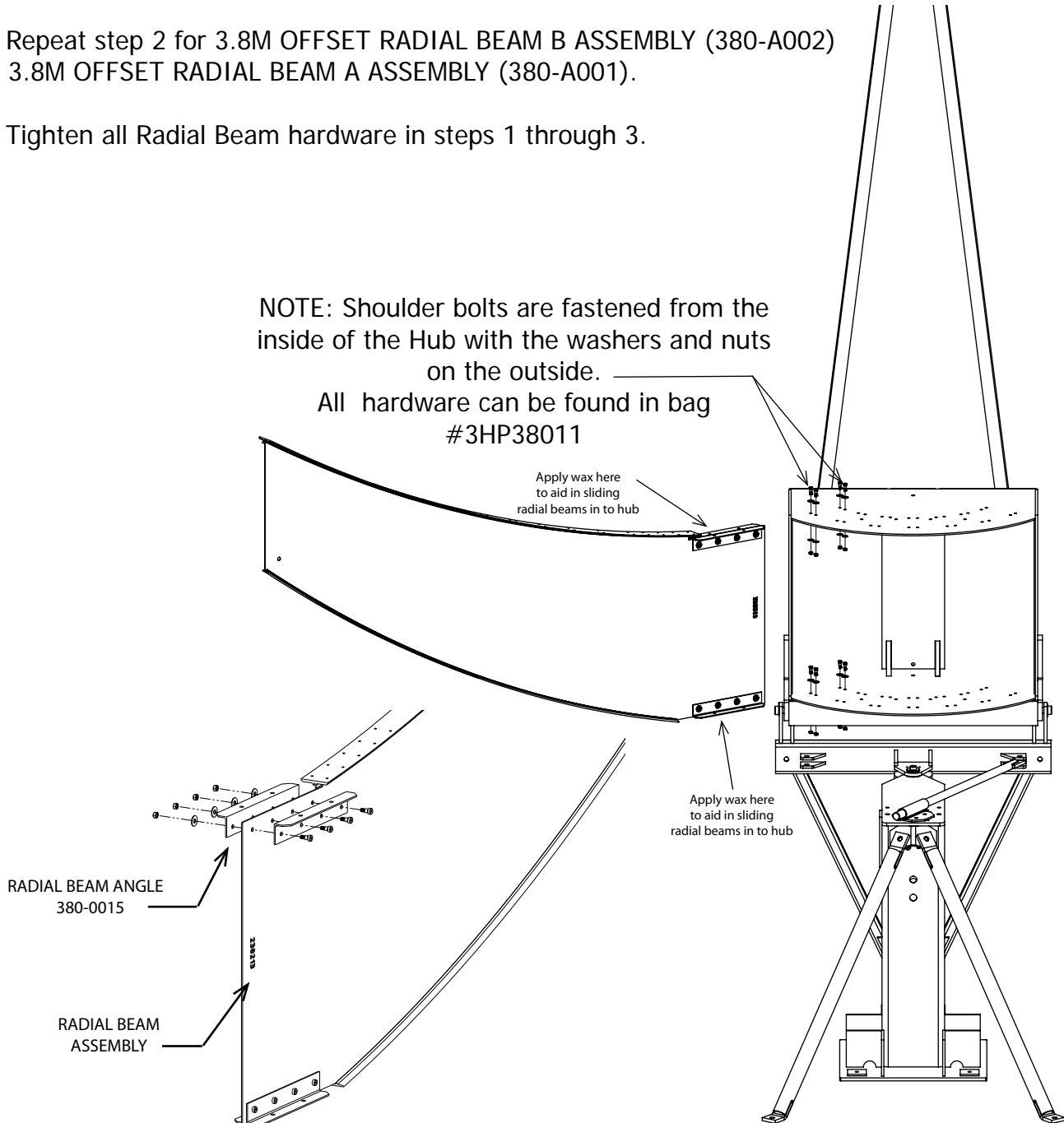

Back Structure Install

1. Pre-assemble all (20) BRKT., 3.8M OFFSET BACK SUPPORT to the Radial Beams using 1/2 x 1-1/4" bolt, 2-washers, 1-nut. Leave loose.
2. Attach 3.8M OFFSET 90" BACK SUPPORT (380-A005).
3. Starting in the middle and working outward, attach (6) 32" RADIAL TIE-DOWN (380-0040) and (4) 45" RADIAL TIE-DOWN (380-0041) using 1/2 x 1-1/4" bolt, 2-washers, 1-nut.
4. Attach (2) ASSY, 3.8M OFFSET 90" BACK SUPPORT (380-A005) to the Hub and Radial Beams as shown.

NOTE: Leave all Frame hardware loose at this time.

NOTE: Assure that all supports angles and frame angles are parallel to to face of the Hub.

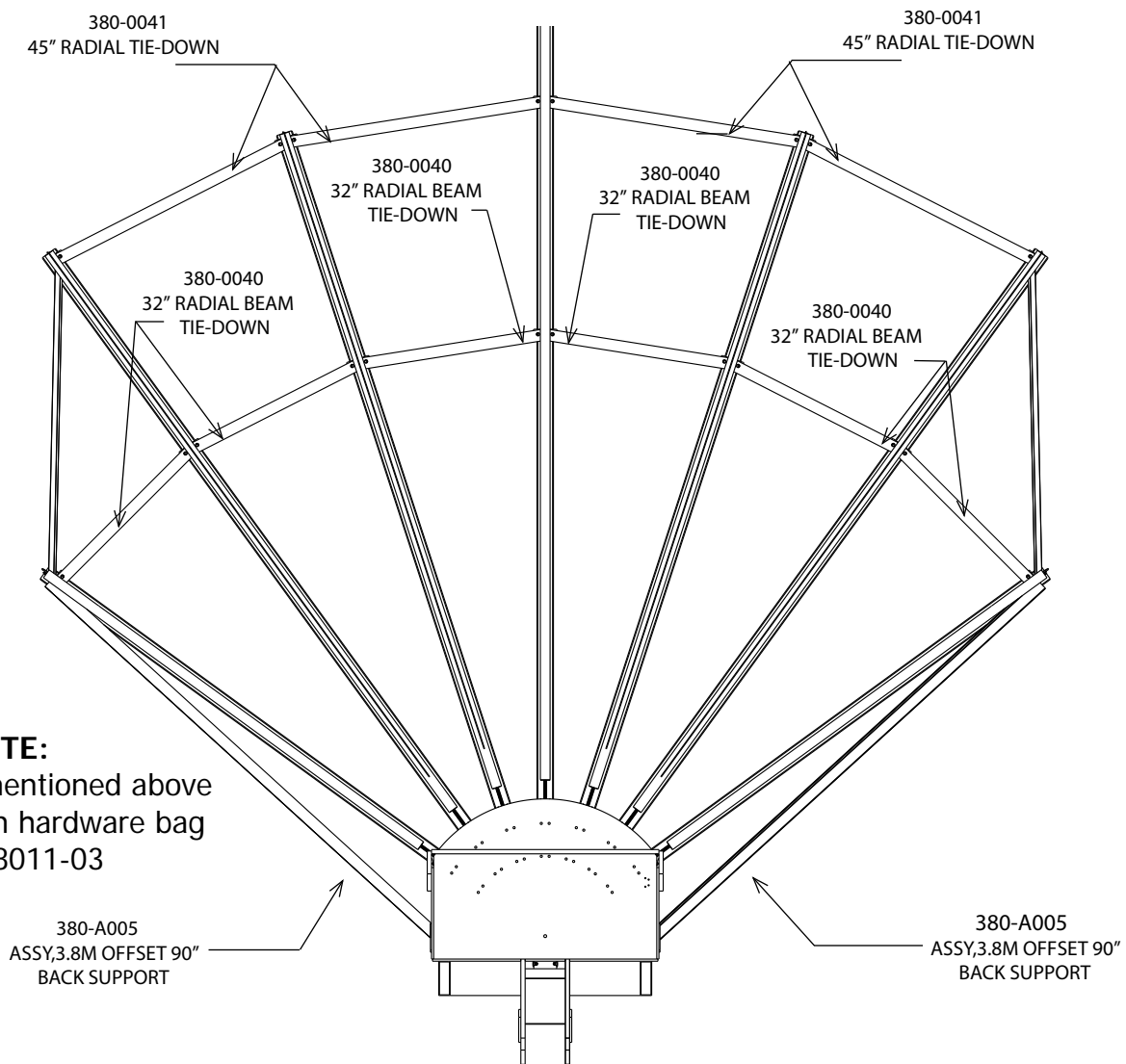
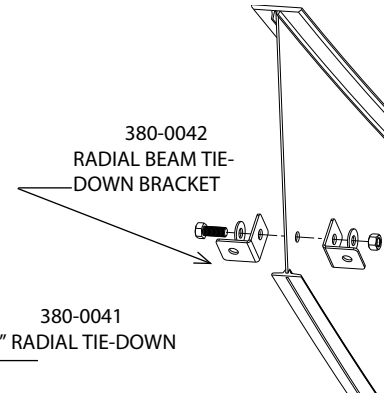

NOTE:

All hardware mentioned above can be found in hardware bag #3HP38011-03

Panel Install

1. Starting with 3.8m OFFSET PANEL "C" LEFT (380-0020):
Place the panel into place onto the left-most radial beam as pictured below.
Fasten with 1/4 x 1/2 truss head bolts. Leave bolts 1/2 turn loose at this time.
2. Fasten the next panel as mentioned above. Continue until all panels have been placed.
(See inset picture for panel placement)
3. Tighten all hardware at this time. See note below for tightening procedure. (If you must step into reflector please DO NOT step in center of panels. Keep weight in radial beams ONLY.)

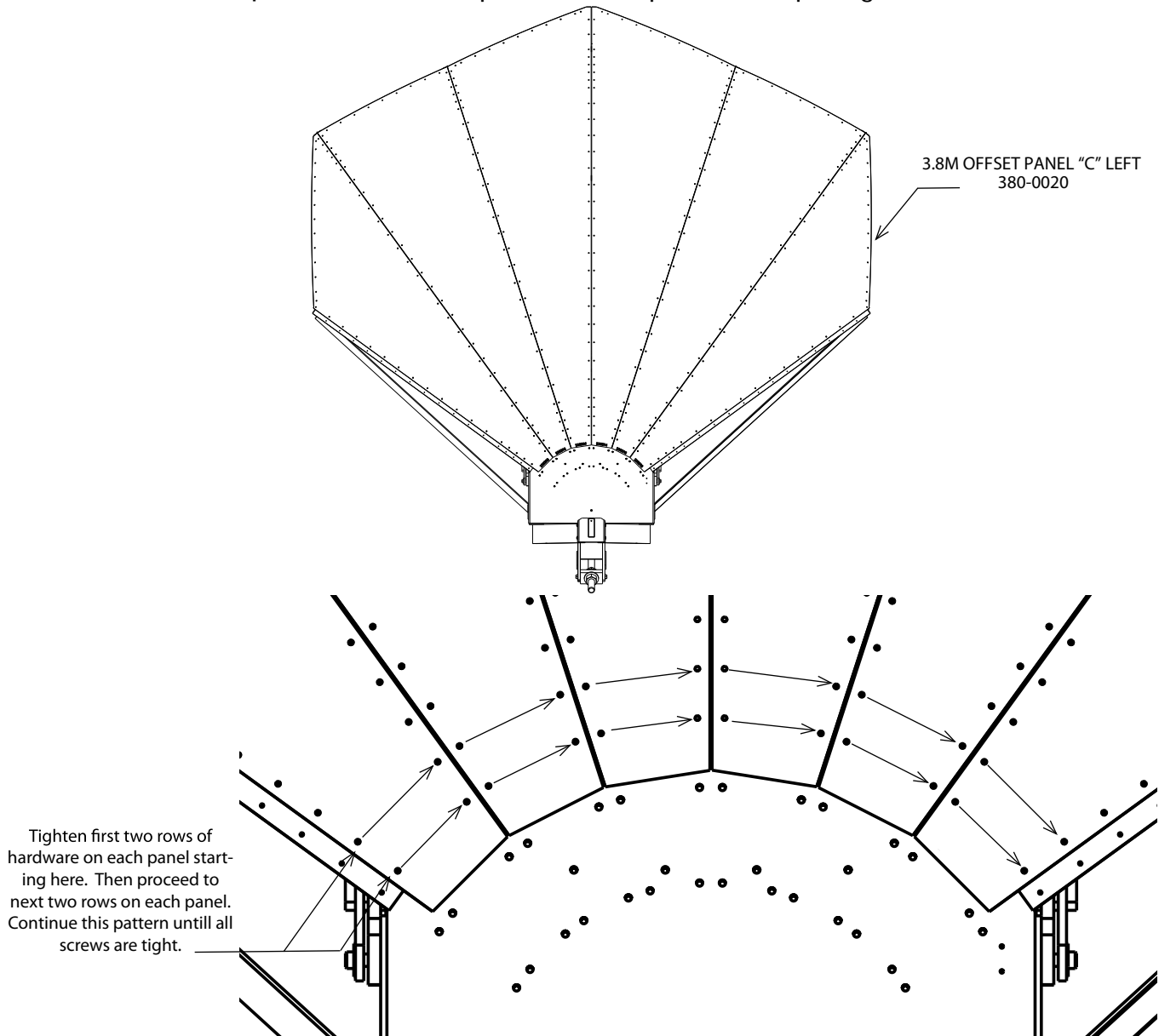

NOTE:

Left and right orientation are as you are standing BEHIND the reflector assembly. The above drawing is pictured as you are standing INFRONT of the reflector assembly. Left and right designated panels are NOT interchangeable. All above mentioned hardware can be found in hardware bag 3HP38011-01

Kerfing Install

1. Attach kerfing segments to outer most part of panels as pictured below using same 1/4-20 screws used on panels.
2. When all panel, kerfing and hardware is in place, tighten all panels and back structure angle bolts starting near the hub and working outward.

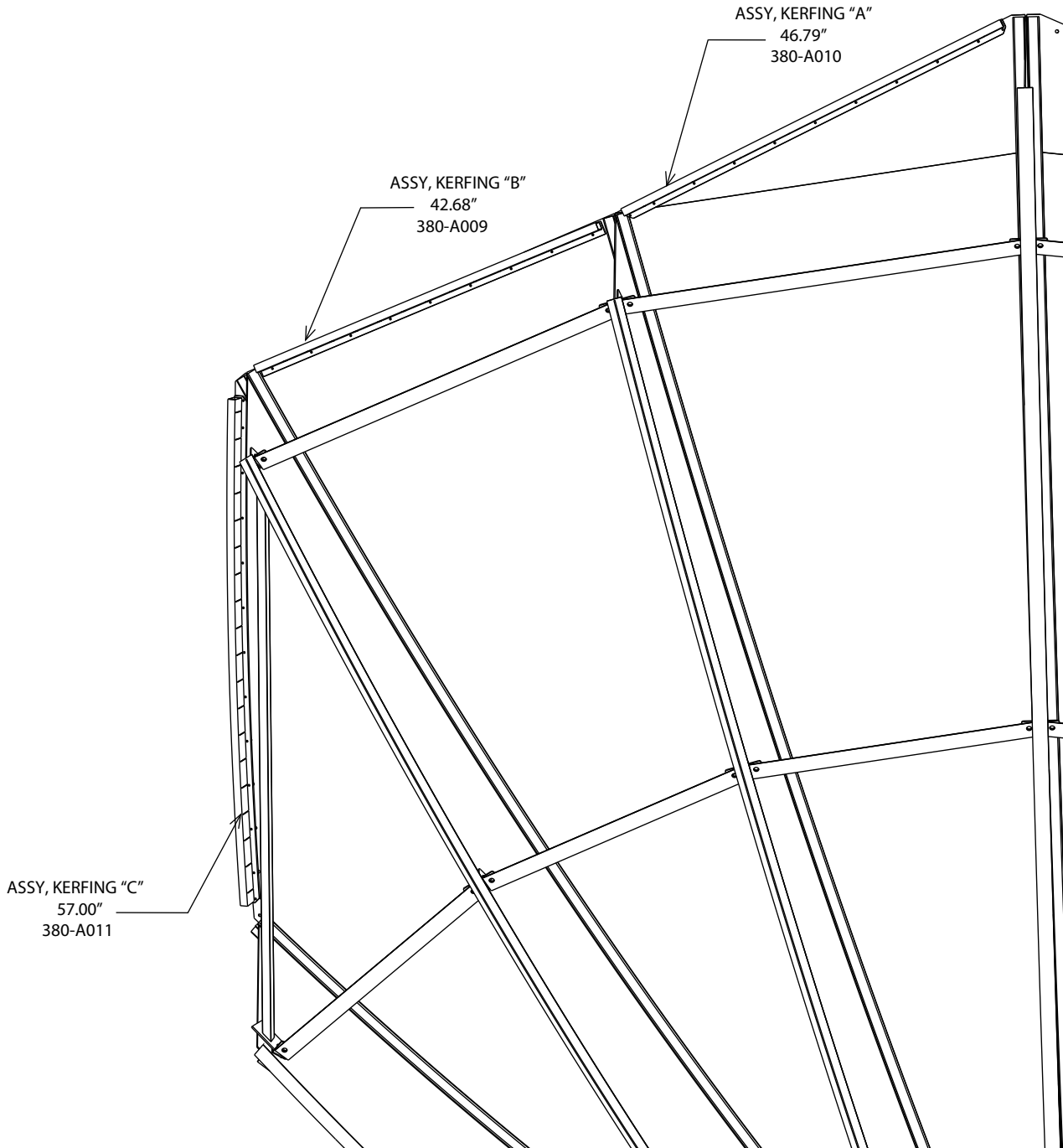

Antenna Pointing

NOTE: The Reflector contains a 23 degree offset look angle. Therefore, when the face of the reflector looks perpendicular to the ground, the antenna is actually looking 23 degrees in elevation. The antenna look angle is actually the top side of the Feed Support Plates as shown below.

FOR FIXED MOUNT POINTING:

1. Adjust the reflector up or down in elevation by turning the two 2" hex nuts on the Elevation Rod Assembly until the desired elevation is measured (taking Elevation angle measurement from the Feed Support Arms).
2. Azimuth Adjustment: With the electronics set to acquire the satellite, use the double-nut threaded adjustment on the Azimuth Rod.

NOTE: If signal is not found on first pass of Azimuth, adjust elevation up or down in 2 deg increments until signal is found.

3. Peak the satellite signal by fine adjustments made in both azimuth and elevation until the optimum signal is achieved.

NOTE: Adjust, tighten, recheck until optimum signal is reached in both Azimuth and Elevation.

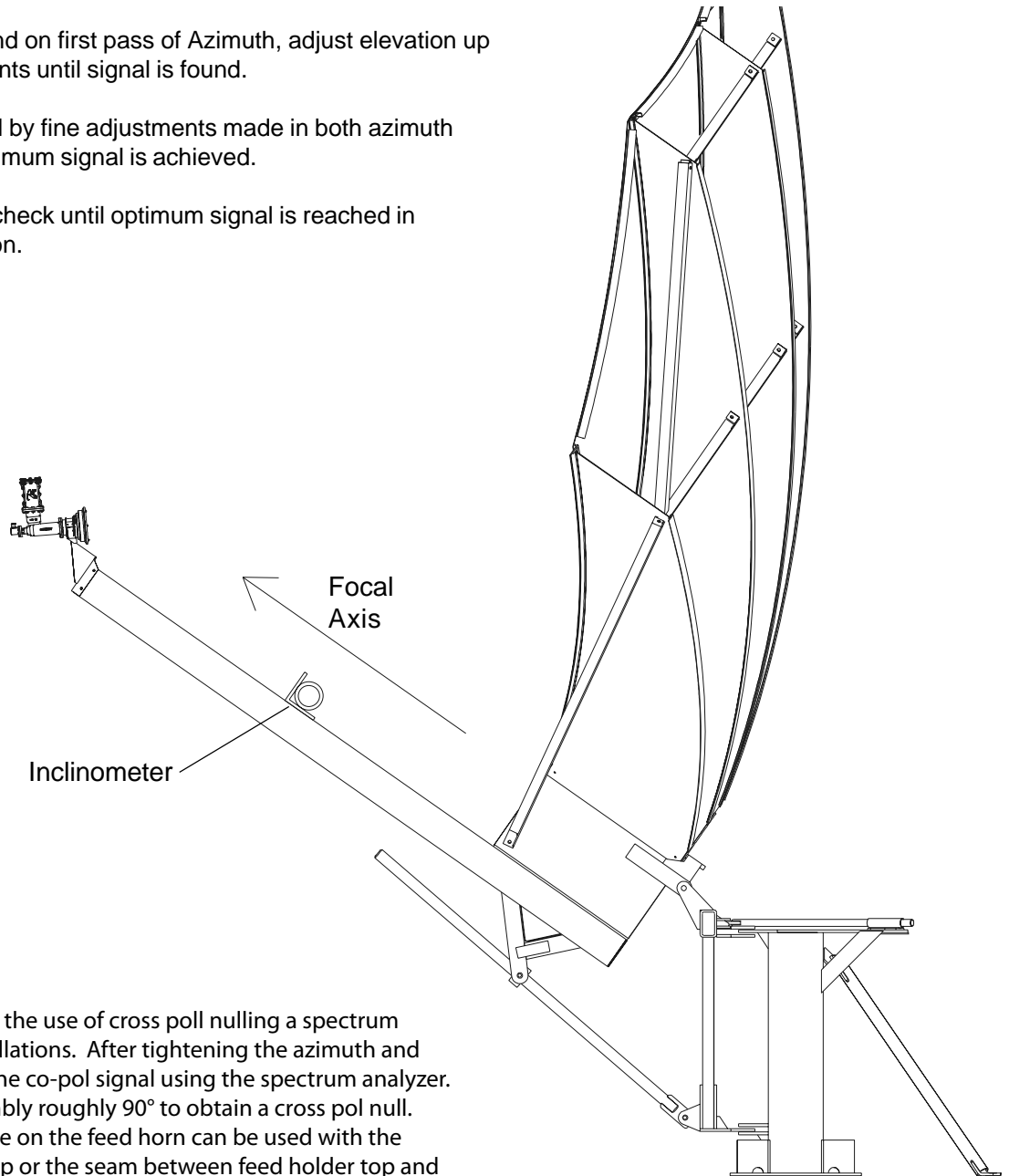

4. Challenger recommends the use of cross poll nulling a spectrum analyzer during Tx/Rx installations. After tightening the azimuth and elevation hardware, peak the co-pol signal using the spectrum analyzer. Then rotate the feed assembly roughly 90° to obtain a cross pol null. Fine tune the null. The scale on the feed horn can be used with the tick mark on feed holder top or the seam between feed holder top and bottom. The tick mark and seam are 90° apart. Note that changes may be necessary to the resolution and video bandwidth to bring the signal above the noise floor. Notes that angel of optimum cross pol null. Rotate the feed back exactly 90° and tighten the feed clamp.

Grounding

Grounding Antenna Feed Cables

1. Ground antenna feed cables in accordance with current National Electric code and local electric codes. The illustration shows a typical grounding method.

Clamps that provide a solid connection between ground wire and a ground source should be used.

Grounding Non-Penetrating Mount Frame (if applicable)

1. Ground the Non-Penetrating mount frame. The illustration shows a typical grounding method.

Refer to the NEC Section 810 and local electric codes for specific instructions on grounding the remaining end of the ground wire.

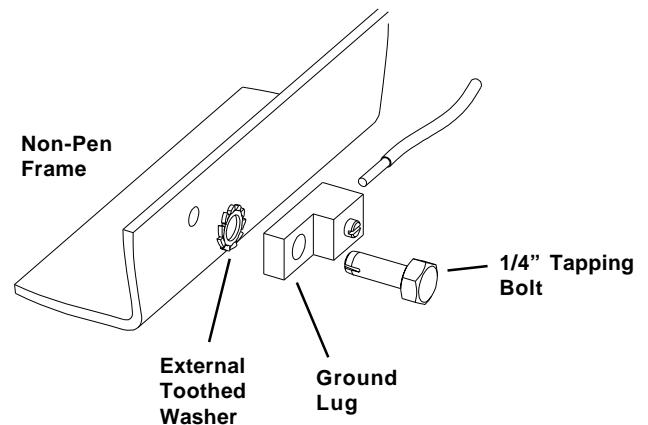
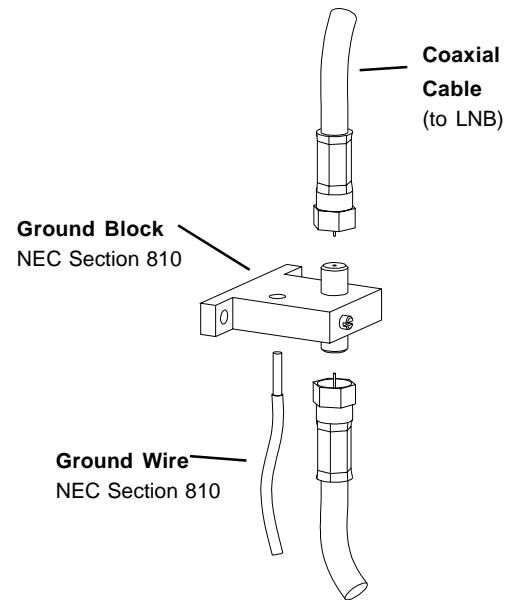

Antenna Pointing

1. Begin by obtaining the correct Az/EI pointing data for the satellite of interest based upon your site location.

2. Using an inclinometer or position readout form controller placed on the enclosure drum surface, position the antenna to the specified elevation angle.

3. Manually scan the antenna (back-and-forth in the azimuth around the direction of the specified azimuth angle) to achieve the maximum transponder signal.

4. Next, repeat the procedure for elevation.

5. Repeat this procedure alternating between the azimuth and elevation until maximum transponder signal is achieved.

- NOTES:**
1. SOIL BEARING CAPACITY = 2000 PSF
 2. CONCRETE, 3000 PSI AT 28 DAYS, POURED & VIBRATED AGAINST UNDISTURBED SOIL. ALLOW (24) HOURS FOR CONCRETE TO SET BEFORE INSTALLATION OF ANTENNA. ESTIMATED CONCRETE USAGE = 8.7 YARDS
 3. USE #5 (Ø5/8) RE-BAR IN CONCRETE PAD. ESTIMATED USAGE = 478 FT.
 4. ANCHOR RODS, WASHERS, AND NUTS SHALL BE GRADE 5 OR BETTER, GALVANIZED. (HARDWARE & TEMPLATE KIT IS AVAILABLE FROM CHALLENGER COMMUNICATIONS.)
 5. WHEN THE FROST LINE IS BELOW (10) INCHES THE BASE SLAB/SOIL REQUIRES SPECIAL DESIGN CONSIDERATIONS TO PREVENT HEAVING; CONSULT A LOCAL LICENSED CIVIL ENGINEER.
 6. LIGHTNING AND GROUNDING PROVISIONS PER LOCAL REGULATIONS.

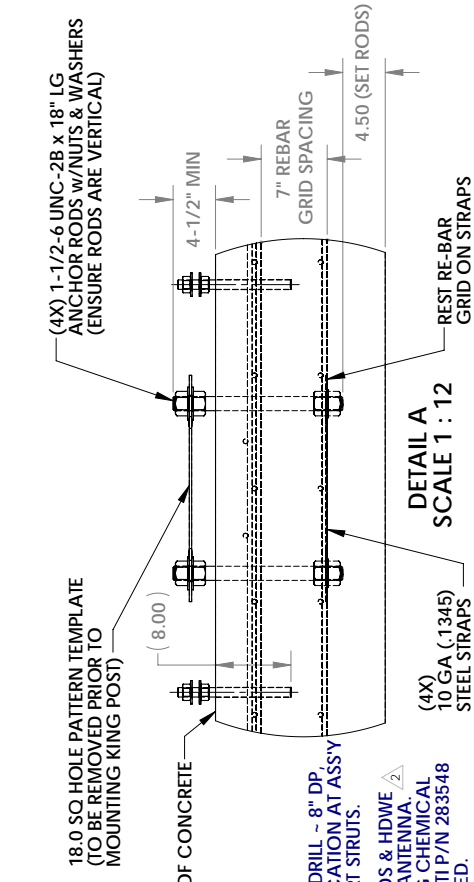
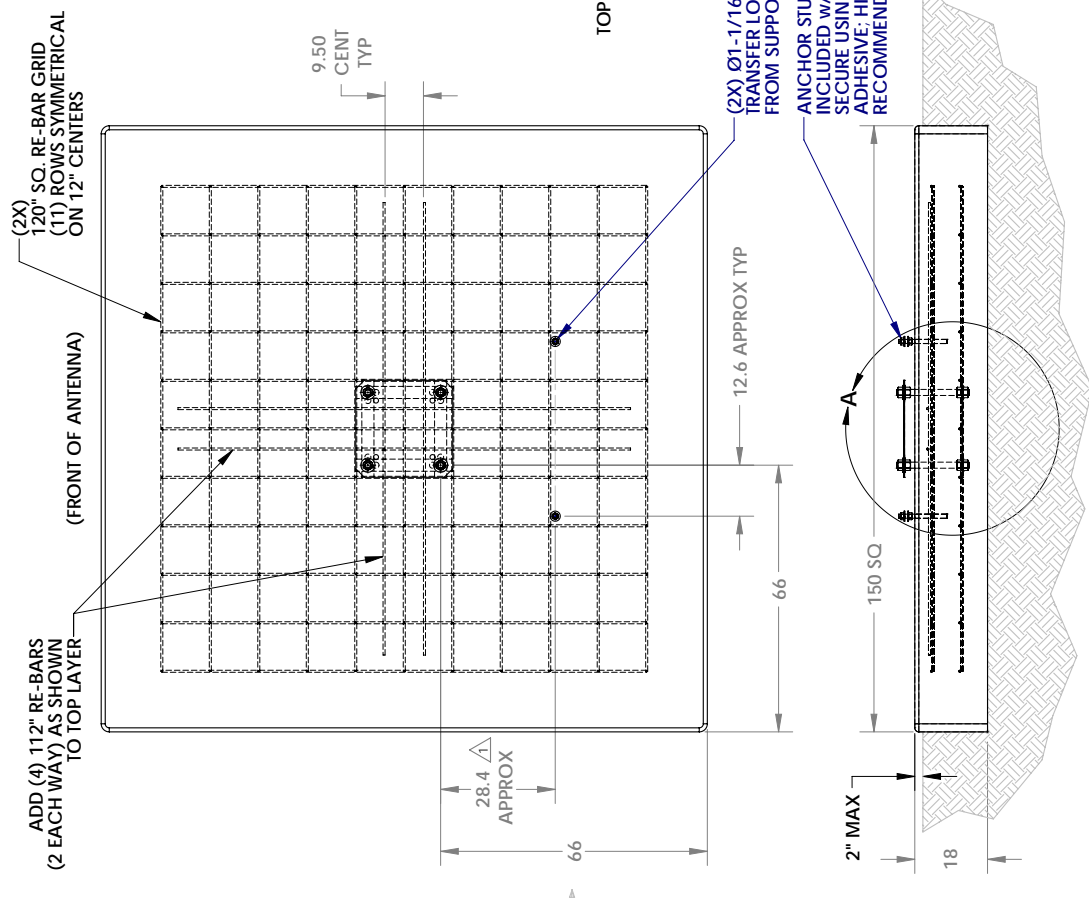

3.8m OFFSET FOUNDATION

(2X) Ø1-1/16 DRILL ~ 8" DP. TRANSFER LOCATION AT ASS'Y FROM SUPPORT STRUTS.
ANCHOR STUDS & HDWE INCLUDED W/ANTENNA. SECURE USING CHEMICAL ADHESIVE: HILTI P/N 283548 RECOMMENDED.

Mototized Mount Option Assembly

1. Assemble the Elevation Jack assembly to the Hub assy as shown using 2- 3/4x2-1/2" shoulder bolts, 2- 3/4" washers (bolt side), 2- 5/8" washers (nut side), and 2- 5/8" nylok nuts.

2. Assemble the Jack extension rod to the Yoke assy using 1- 3.4x4" bolt, 2 washers, and nylok nut.

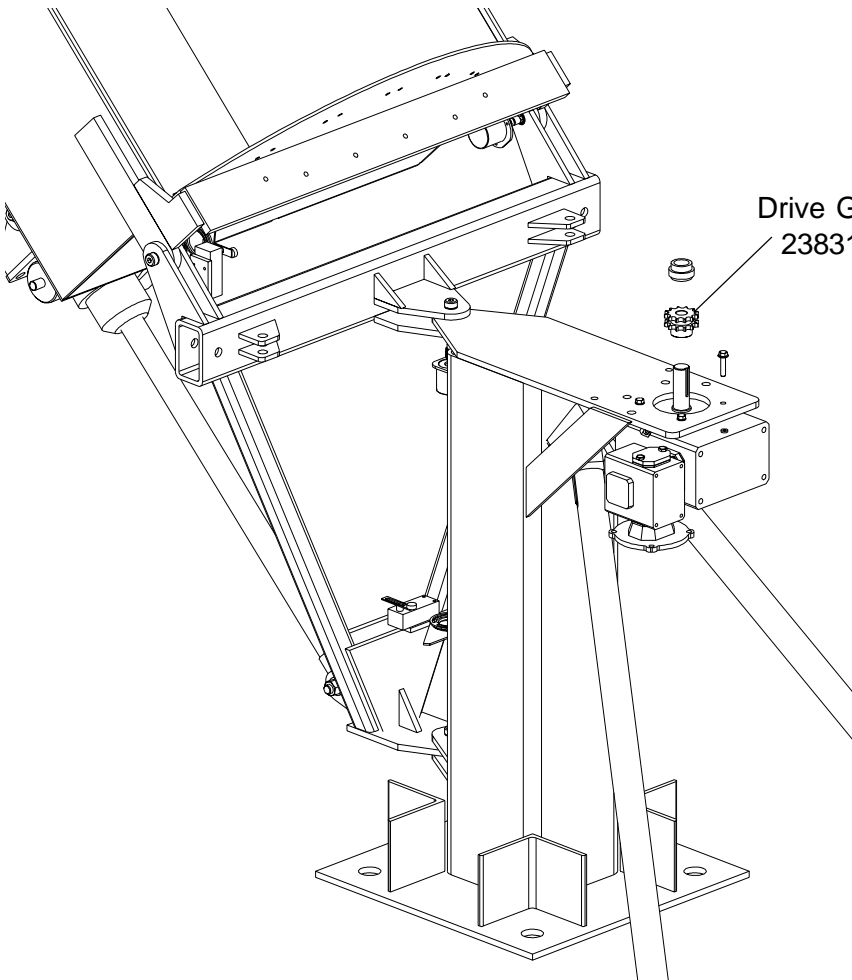
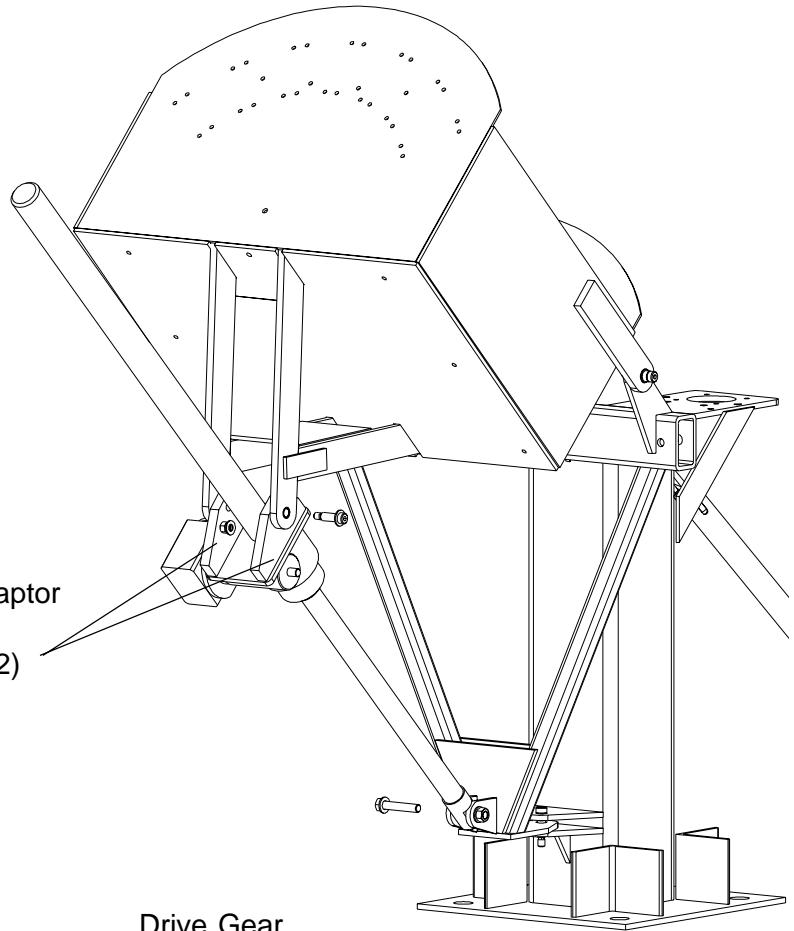

3. Mount the Azimuth GearDrive to the KingPost Mast assembly using 4- 3/8x1-1/2" bolts and washers.

4. Assemble the keyed drive sprocket, key and guide bushing to the drive shapft as shown. Leave loose to adjust height later.

Appendix B (continued)

Mototized Mount Option Assembly

5. Place the D-Ring assy onto the mast and yoke assy's as shown. Use the "Resolver Shoulder Bolt assy" for the D-ring-Yoke assy pivot.

6. Assemble the D-Ring to the Yoke using 2- 1/2x1-1/2" Flat Socket Head bolts, 2 washers, and 2 nylok nuts.

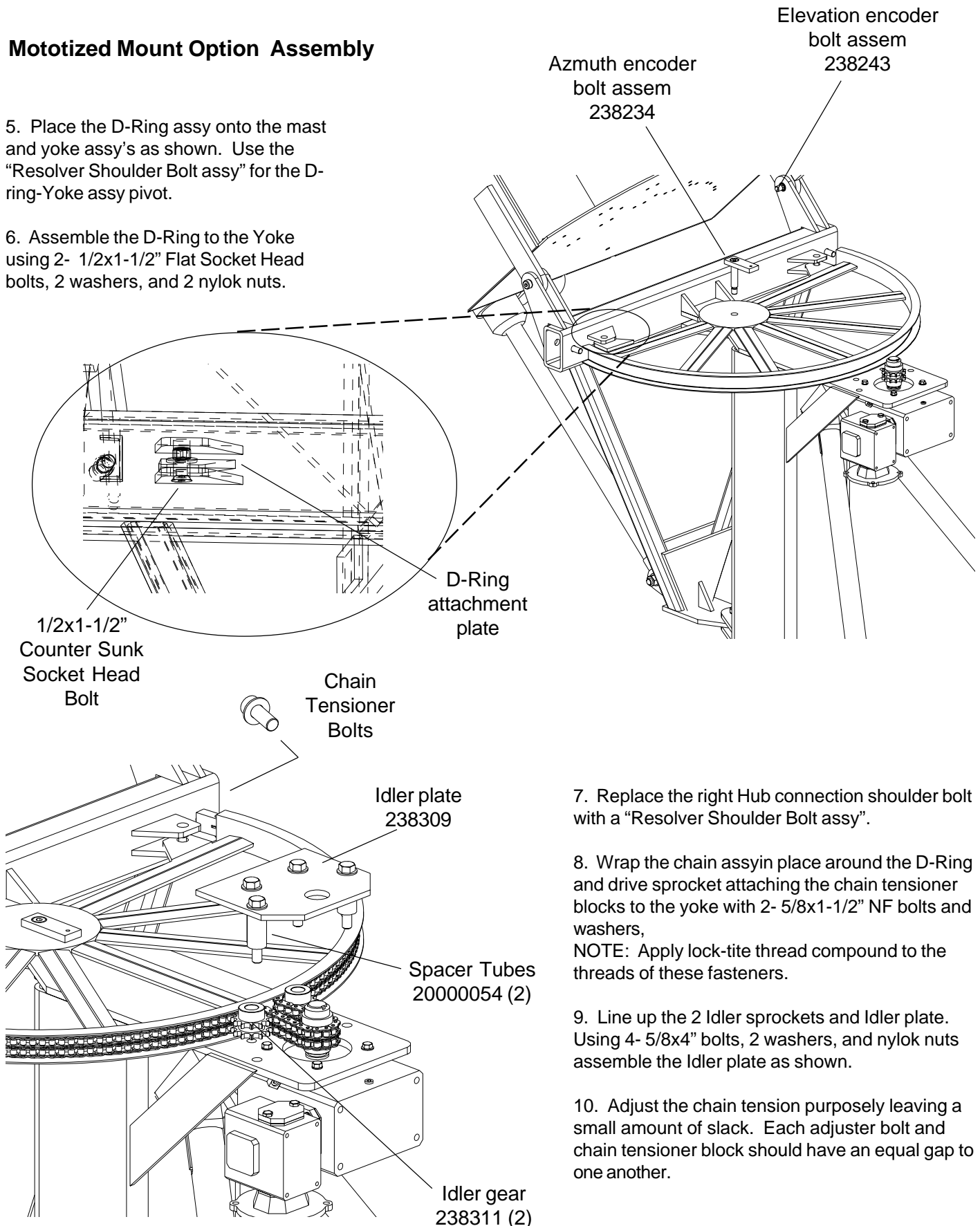

7. Replace the right Hub connection shoulder bolt with a "Resolver Shoulder Bolt assy".

8. Wrap the chain assy in place around the D-Ring and drive sprocket attaching the chain tensioner blocks to the yoke with 2- 5/8x1-1/2" NF bolts and washers,
NOTE: Apply lock-tite thread compound to the threads of these fasteners.

9. Line up the 2 Idler sprockets and Idler plate. Using 4- 5/8x4" bolts, 2 washers, and nylok nuts assemble the Idler plate as shown.

10. Adjust the chain tension purposely leaving a small amount of slack. Each adjuster bolt and chain tensioner block should have an equal gap to one another.

Mototized Mount Option Assembly

11. Mount Elevation Limit Switch and bracket, as shown, to yoke cross tube
12. Mount Azimuth Limit Switch to bracket as done in previous step. Mount bracket to King Post Mast as shown.

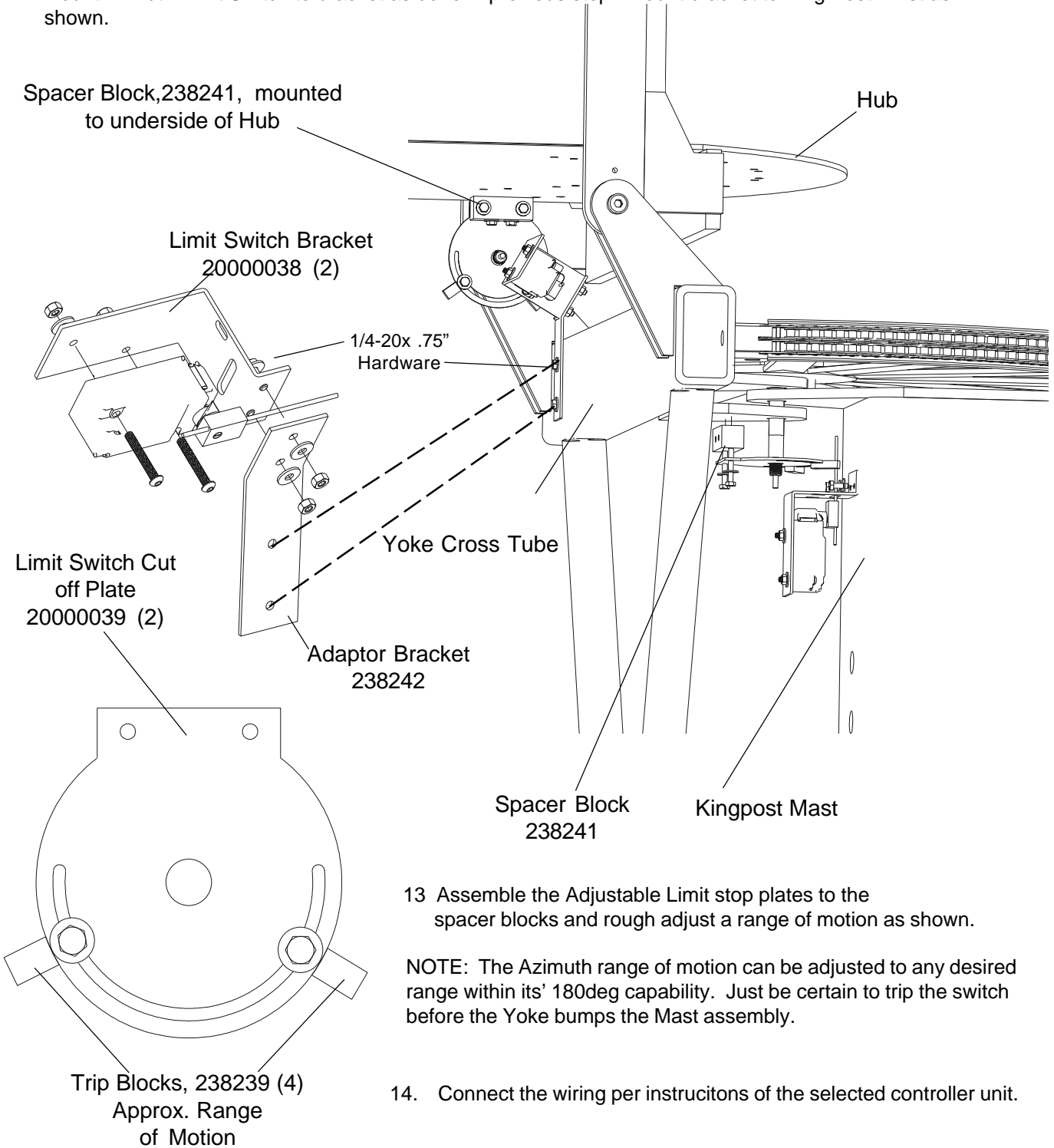

Appendix B (continued)

Mototized Mount Option Assembly

15. Assemble the Drive motors to the Elevation acutator and the Azimuth Gearbox.

Recommended Maintenance Schedule

Maintenance Item	Comment
Check Azimuth gearbox oil level. Oil level should be even with fill plug. Add oil as required to maintain proper level	
Check Azimuth chain and sprockets for dirt. Clean and lubricate as needed.	Lubricate with good commercial quality spray lubricant
Check Elevation gearbox oil level. Oil level should be even with fill plug. Add oil as required to maintain proper level.	
Check Elevation Jack boot for damage or deterioration. Clean dirt and oil from boot as required.	Use soap and water for cleaning
Check cables and connectors for damage or deterioration. Clean as required to prolong life.	Use electrical contact cleaner as required
Check wiring for strain relief, damage or deterioration. Clean as required to prolong life.	

Troubleshooting

Troubleshooting Tips

Item	Symptom	Recommended Action
1	Antenna will not drive.	<ul style="list-style-type: none"> •Check for mechanical interference •Check power source •Check fuses in drive cabinet •Check limit switch status/operation •Refer to controller maintenance manual for further options
2	Feed polarization will not drive.	<ul style="list-style-type: none"> •Check for mechanical interference •Check power source •Check fuses in drive cabinet •Check limit switch status/operation •Refer to controller maintenance manual for further options
3	Low signal strength	<ul style="list-style-type: none"> •Check pointing of antenna and re-peak as required if mis-pointed •Check feed assy for damage or water ingress •Check waveguide for damage or water ingress •Check cables for damage or poor connections

Feed Adjustment (Polarity tuning)

1. Adjust the Feed to the appropriate skew angle using the provided scale reference.

NOTE: Refer to the chart on back for polarization angle. Elevation and polarity are both dependent on site azimuth and the difference between satellite and site longitude.

NOTE: Some satellites have a slant angle with respect to the satellite belt angle. Contact the satellite operator for details.

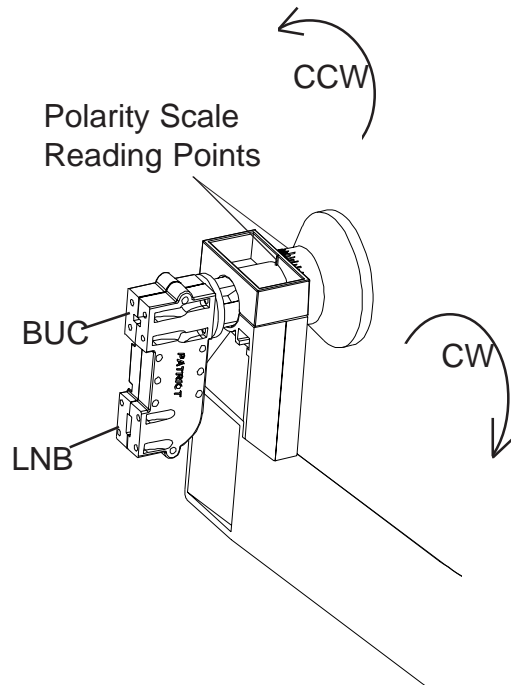

Feed Rotation Chart

Install site west of satellite	Install site East of satellite	
CW	CCW	Northern Hemisphere
CCW	CW	Southern Hemisphere

Feed Assembly

1. Attach the relevant Feed Assembly.
2. Insert the Feed Assembly into the Feed holder and assemble to the Feed Support Tube using the hardware illustrated below.
3. Insert the Feed Support Tube into the support tube.

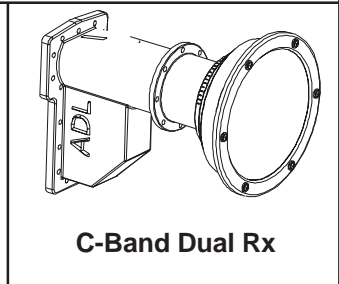
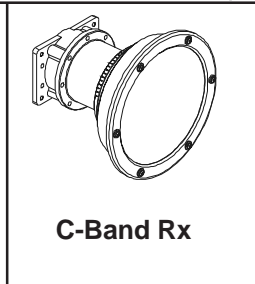
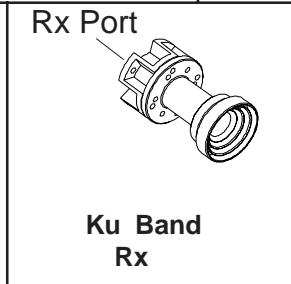
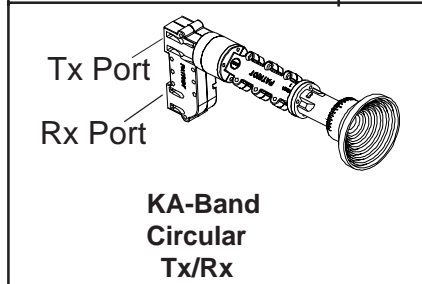
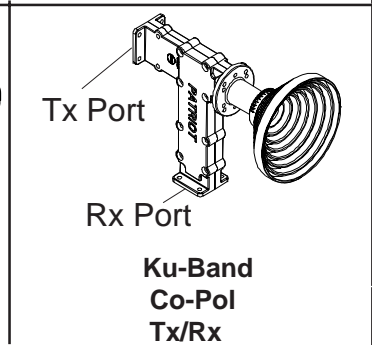
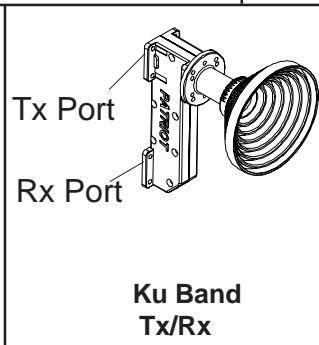
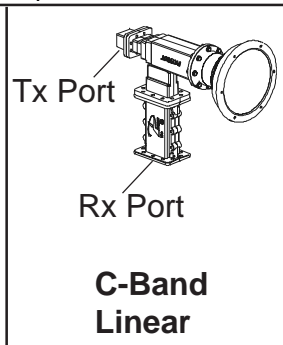
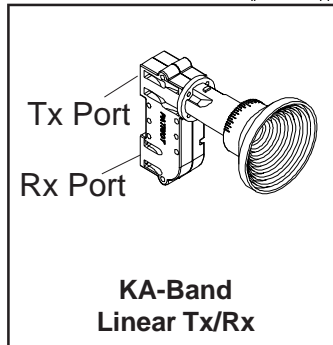
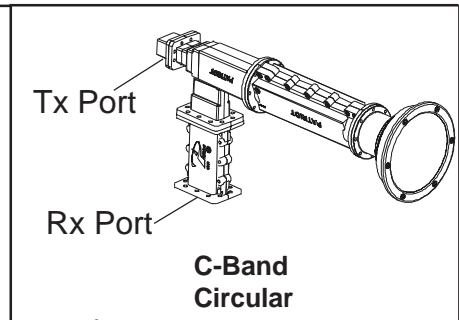
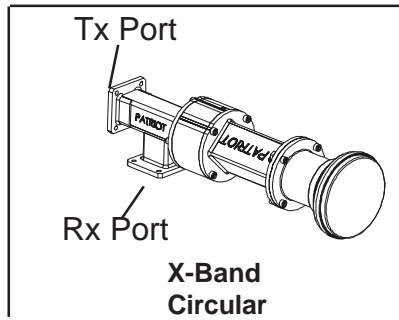
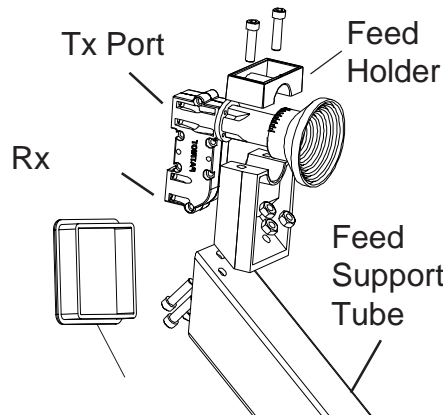

Electrical

	C Band		Ku Band
	Linear	Circular	
Tx Band(GHz)	5.85 - 6.725	5.85 - 6.425	13.75 - 14.5
Rx Band(GHz)	3.4 - 4.2	3.625 - 4.2	10.7 - 12.75
Tx Gain dBi (Midband)	46.2	46.1	53.5
Rx Gain dBi (Midband)	42.1	41.9	51.8
Efficiency		70%	70%
Cross Polarization (on axis)	35dB	(see note)	35dB
Side Lobes		ITU-580-5	
(note- Feed dependent 17.7 or 27.3dB)			

Mechanical

Antenna Size	3.8m (150")
Offset Angle	22.9 degrees
F/D	0.64
Operational Wind	50 m.p.h.
Survival Wind	125 m.p.h.
Operational Temp	-40 to 140 F
Survival Temp	-60 to 180 F
Rain	Operational = 1/2in./hr Survival = 3in./hr
Ice	1 in. Radial -or- 1/2 in. + 60 m.p.h. wind

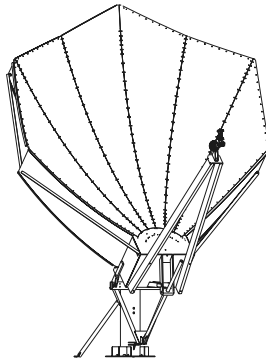

Challenger Communications
704 North Clark Street
Albion, Michigan 49224 USA
Tel: +1 517 680 0125
Fax: +1 517 680 0133
info@challengercommunications.com
www.ChallengerCommunications.com