

704 North Clark Street
Albion, MI 49224 USA
Phone +1 517 680 0125
Fax +1 517 680 0133
www.ChallengerCommunications.com

Challenger Communications

Assembly Manual for the 1.0m Quick-Deploy Antenna System

1.0 meter 6-piece reflector with low-profile base mount

DOC00008 Revised 2015.07.16

CONTENTS

INTRODUCTION	2
MECHANICAL SYSTEM DESCRIPTION.....	3
BACK PACK	3
AZ-EL ANTENNA BASE	3
1.0M REFLECTOR.....	3
.....	3
REFLECTOR ASSEMBLY	6
FEED ASSEMBLY	11

INTRODUCTION

This is a deployable antenna system that comes carefully packed in a portable case. It is a precision instrument that will provide many years of reliable service if assembled and handled with proper care.

Become familiar with these instructions before attempting to work with this antenna system. Completely unpack all the components and identify each one to know it's function and purpose.

MECHANICAL SYSTEM DESCRIPTION

BACK PACK

The antenna is provided in a carrying case measuring approximately 15 x 25 x 12", and weighs approximately 65 pounds. The back pack case has the added features of having roller wheels and an extendable handle for easy handling where applicable. Back Pack shoulder straps are also provided for carrying the case on one's back.

AZ-EL ANTENNA BASE

The Antenna Base is comprised of three detachable legs that have adjustable feet for rough leveling of the assembly, and an Azimuth bearing assembly that the reflector assembles to using a simple "insert and turn" design. The elevation adjustment is accomplished using a turnbuckle that can be rough adjusted in slotted ribs on the back of the reflector, then fine adjusted by turning the body of the threaded turnbuckle. Azimuth adjustment is accomplished by using a turn knob that moves the antenna in a controlled means in the azimuth plane until the RF signal is peaked. A locking handle mechanism then locks it to the desired location.

1.0M REFLECTOR

The Reflector is in six pieces that interlock using dowels, and latches to secure the pieces together into an accurate assembly. Be sure to follow the assembly procedure to properly interlock the pieces. The Feed system is precisely held in place using side struts with ball snaps to the main feed tube. The Feed assembly detaches easily using one ¼ turn knob.

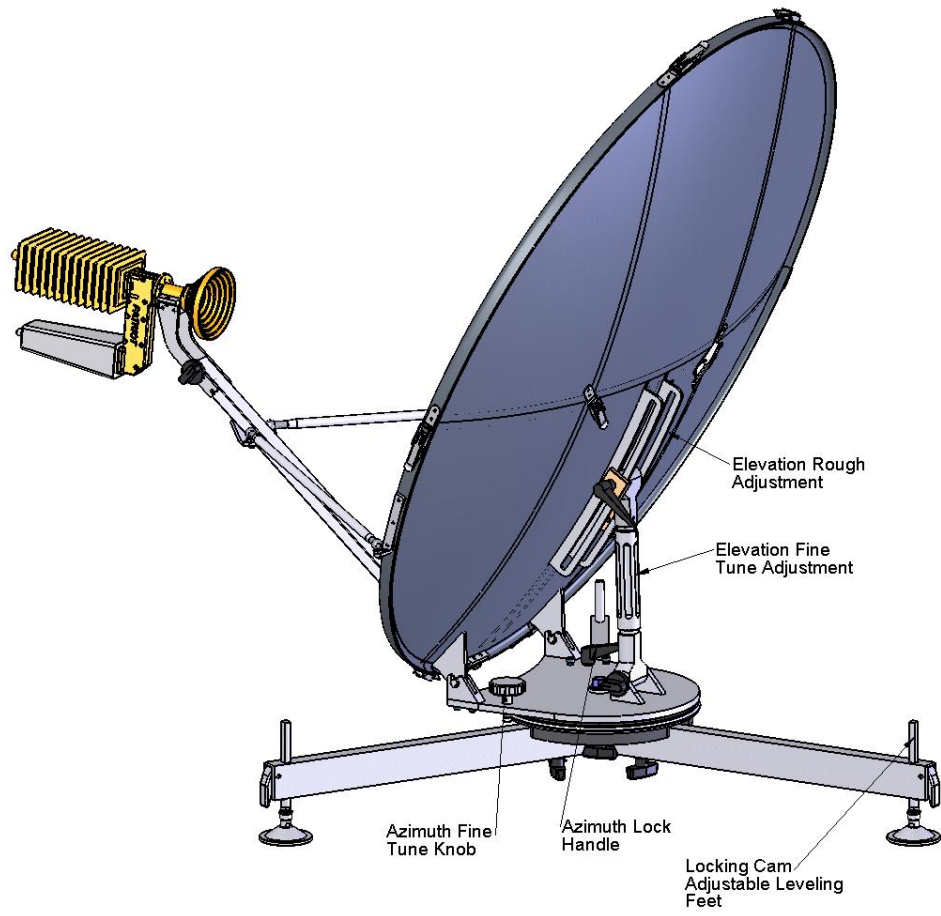

MOUNT ASSEMBLY

The pack has two divided compartments. The topmost compartment has an access flap that is easily opened with its' perimeter zipper. Open this flap and you will find the Mount Assembly parts needed for this stage of the assembly.

1. Slide the Feet assemblies into each of the 3 Leg assemblies as shown. The flatted side of the pin faces the locking cam. Simply turn the cam downward to lock the pin at the desired height.
2. Insert the Leg assemblies onto the bottom side of the AzEl assembly as shown, by aligning the dowels and tightening the threaded fasteners.
3. Roughly level the Mount Assembly using the level bubble as a reference by re-adjusting the Feet assemblies per step 1.

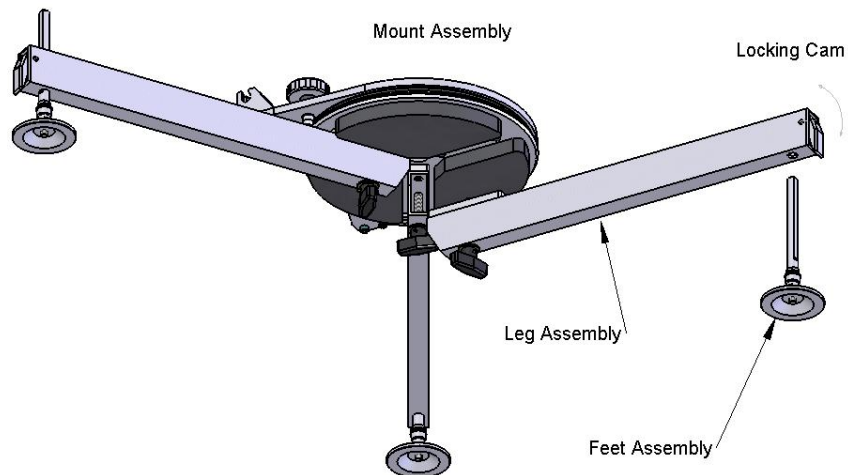

REFLECTOR ASSEMBLY

Two of the reflector panels are in the topmost compartment, and the remaining four as well as the feed support parts are in the bottom compartment which can be accessed with the perimeter zipper around the middle of the case. Remove them taking note how they were packed so they can be repacked accordingly. You will need the bottom-most panel to begin with.

1. Starting with panel B2, guide the mounting lugs into the receiving brackets of the Mount assembly taking care to align the flatted sides of the pins with the flatted sides of the receiver brackets. Then with the indicator line of the knob aligned pointing to the Elevation Turnbuckle, pivot the panel assembly engaging the turnbuckle into the knob pin. When fully engaged turn the knob approximately $\frac{1}{4}$ turn CCW to lock. The panel assembly is now fully locked to the mount assembly.

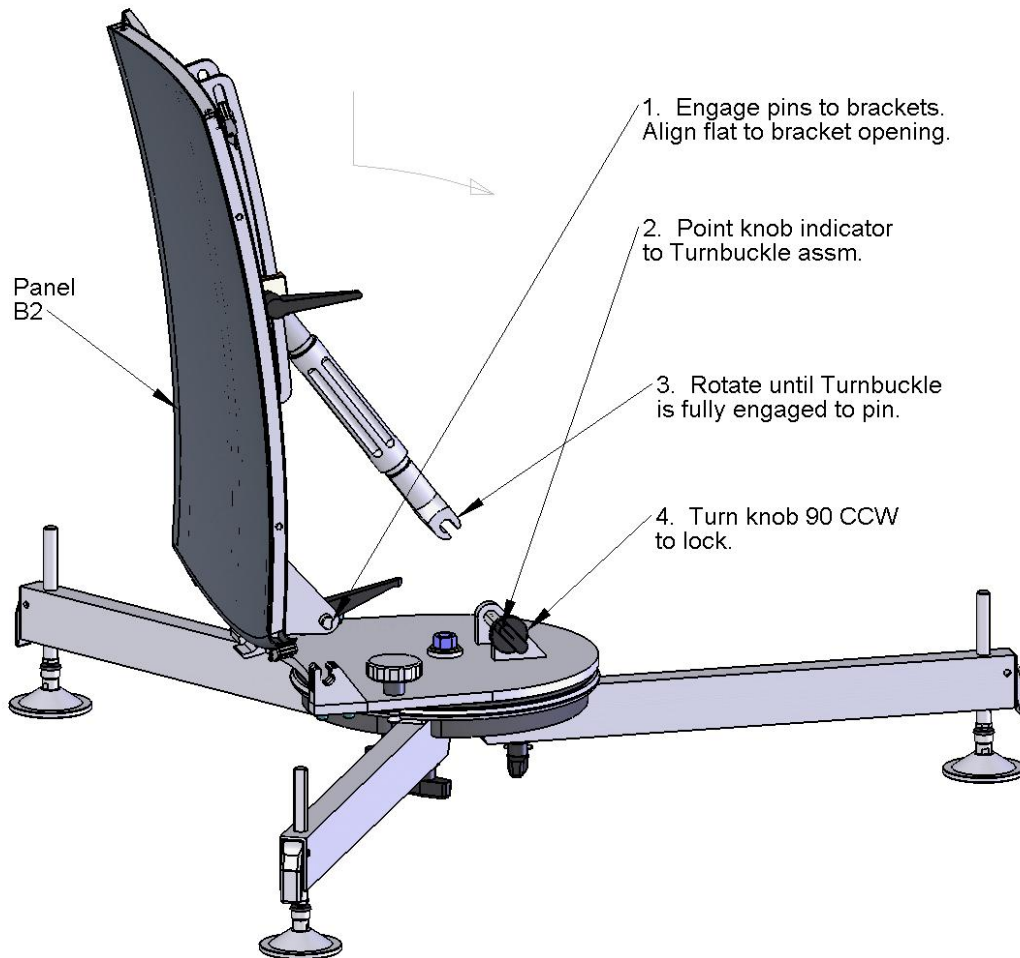

2. Adjust the Elevation to approximately 30 degrees for the installation of the remaining five panels. (Elevation scale is on back of panel B2 near Turnbuckle)

3. Install panel T2 by simply guiding it into position as shown onto the alignment dowels. The panel will stay in place. The seam between the panels should look flush.

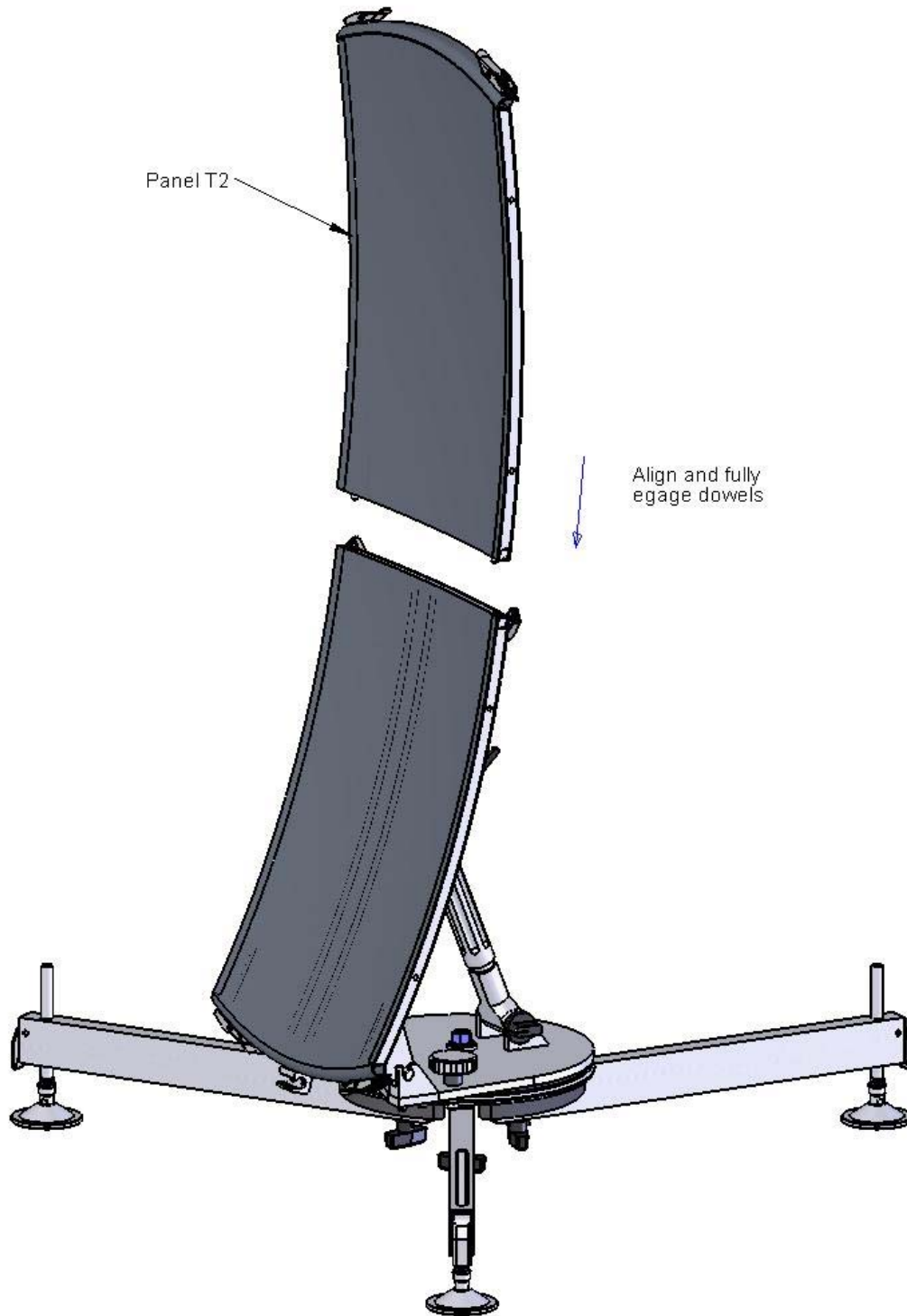

4. Install panel T1 and B3 using the same procedure as in step 3.

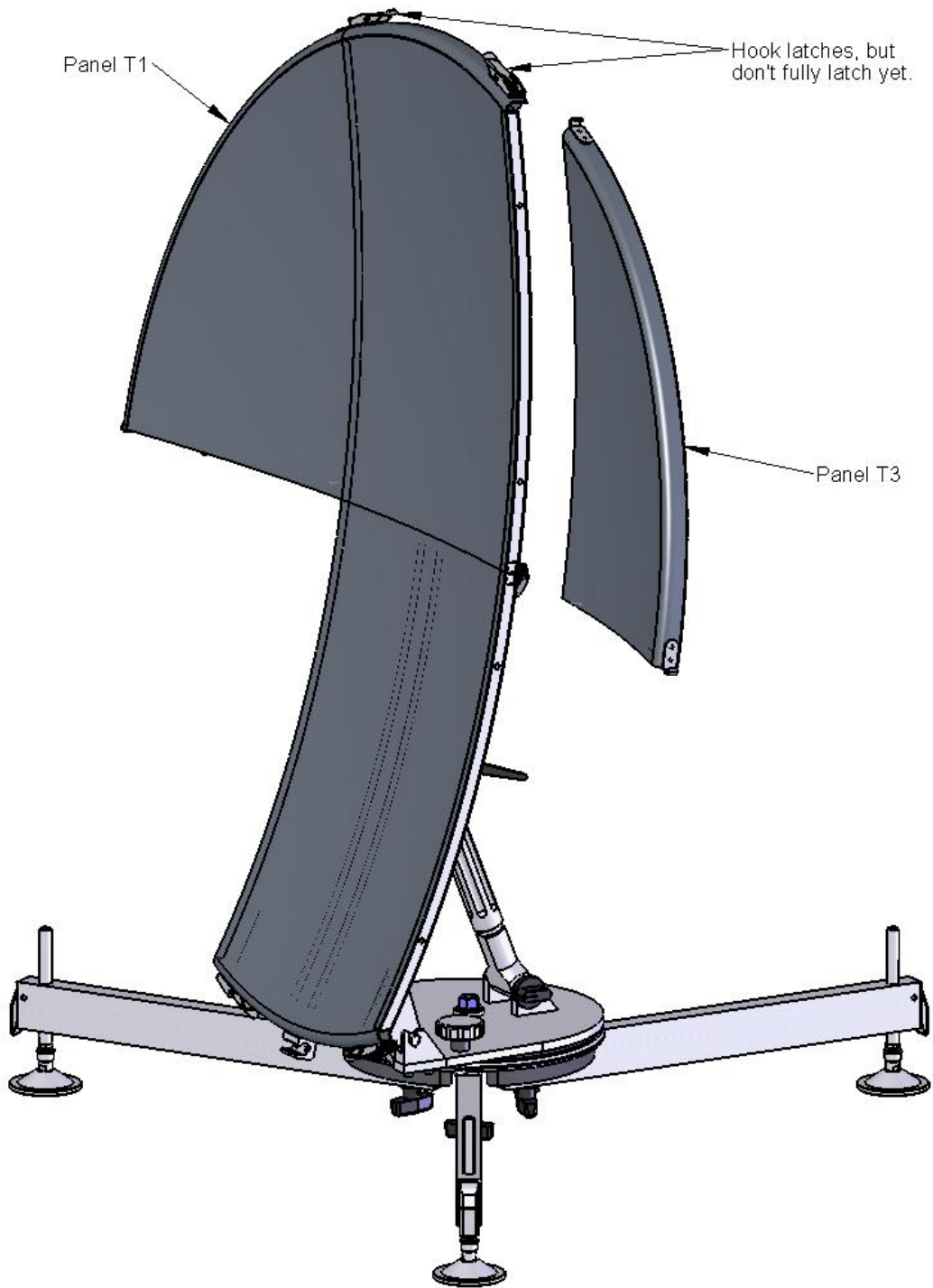

5. Install panel B1 and B3 using the same procedure as in step 3. Panels B1 and B3 will need to be held slightly back and aligned simultaneously with their respective upper panel and its alignment dowel.

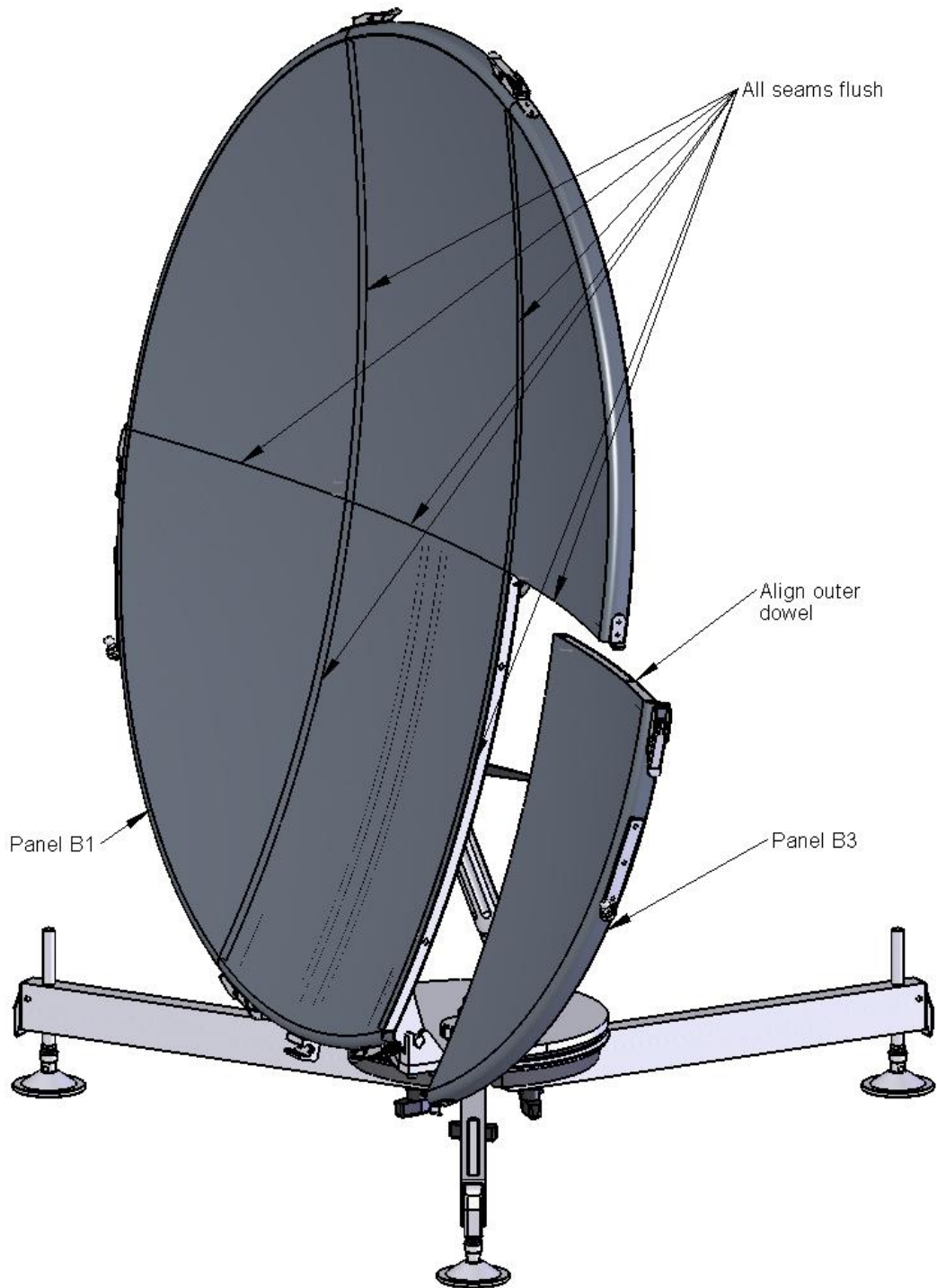

After making sure all seams look flush fasten the two latches on the back of the dish, then fasten the six remaining perimeter latches.

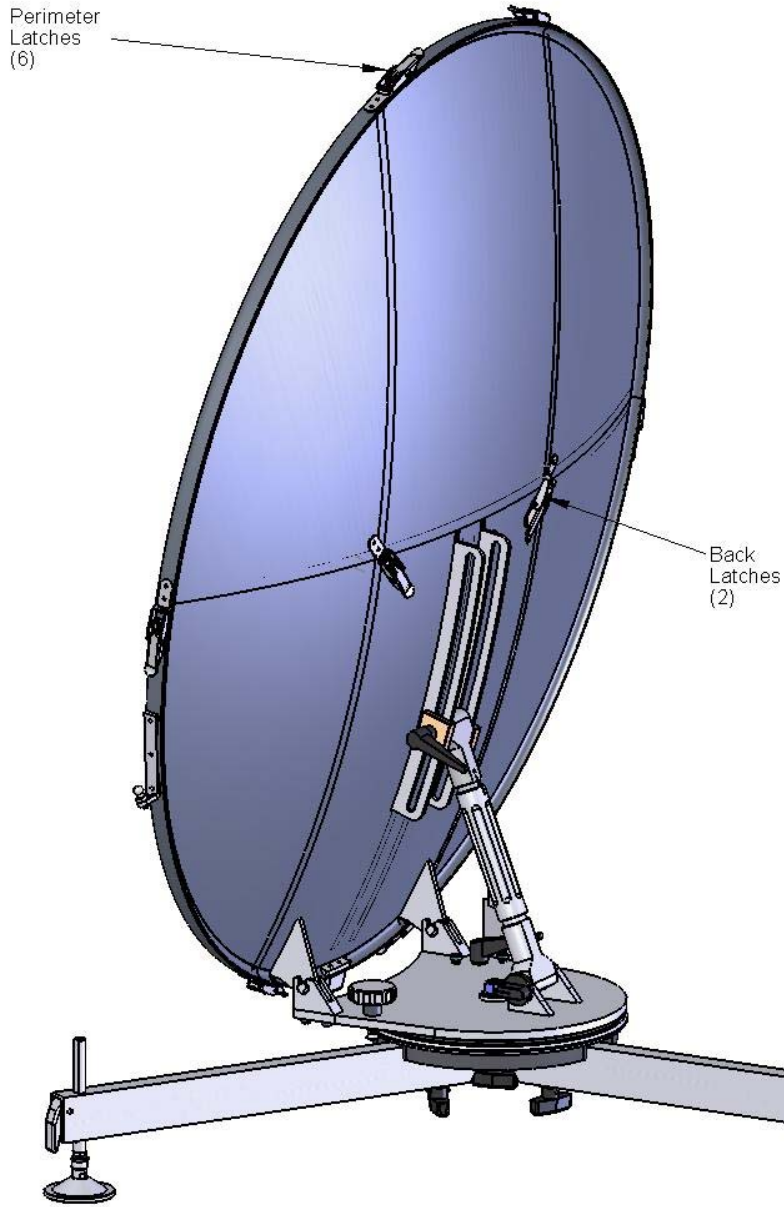

FEED ASSEMBLY

1. With all latches securely latched readjust Elevation Angle to facilitate attachment of the Feed Assembly parts. (Appox. 45deg)
2. Insert the Feed Tube assembly into the receiver at the bottom of panel B2. It must be held at the approximate angle shown. Then once it is fully inserted, rotate upwards to be able to attach the side struts.

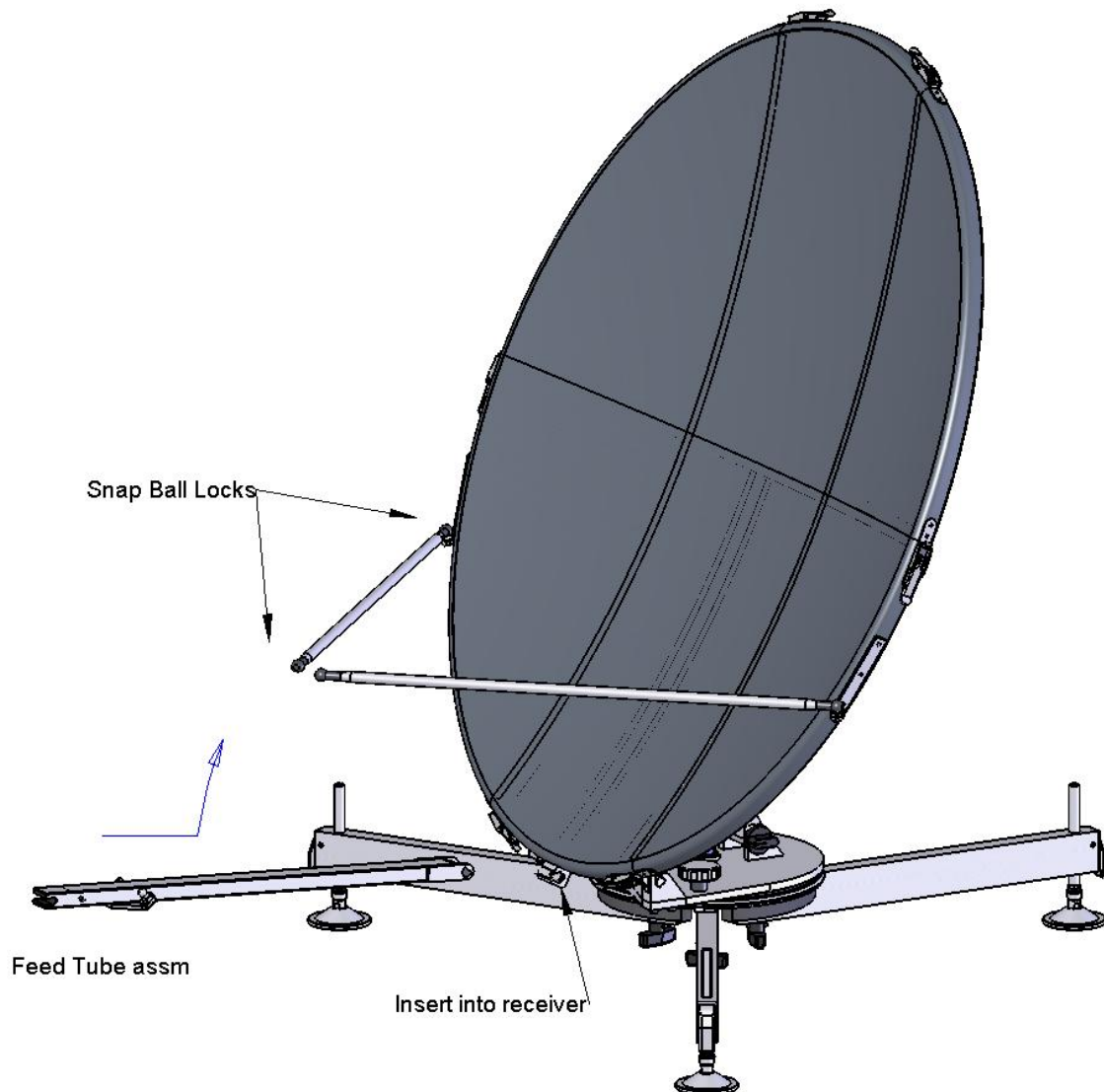

3. Attach each side strut. Snap on to side panels first then snap to corresponding ball snap on the Feed Tube assembly.

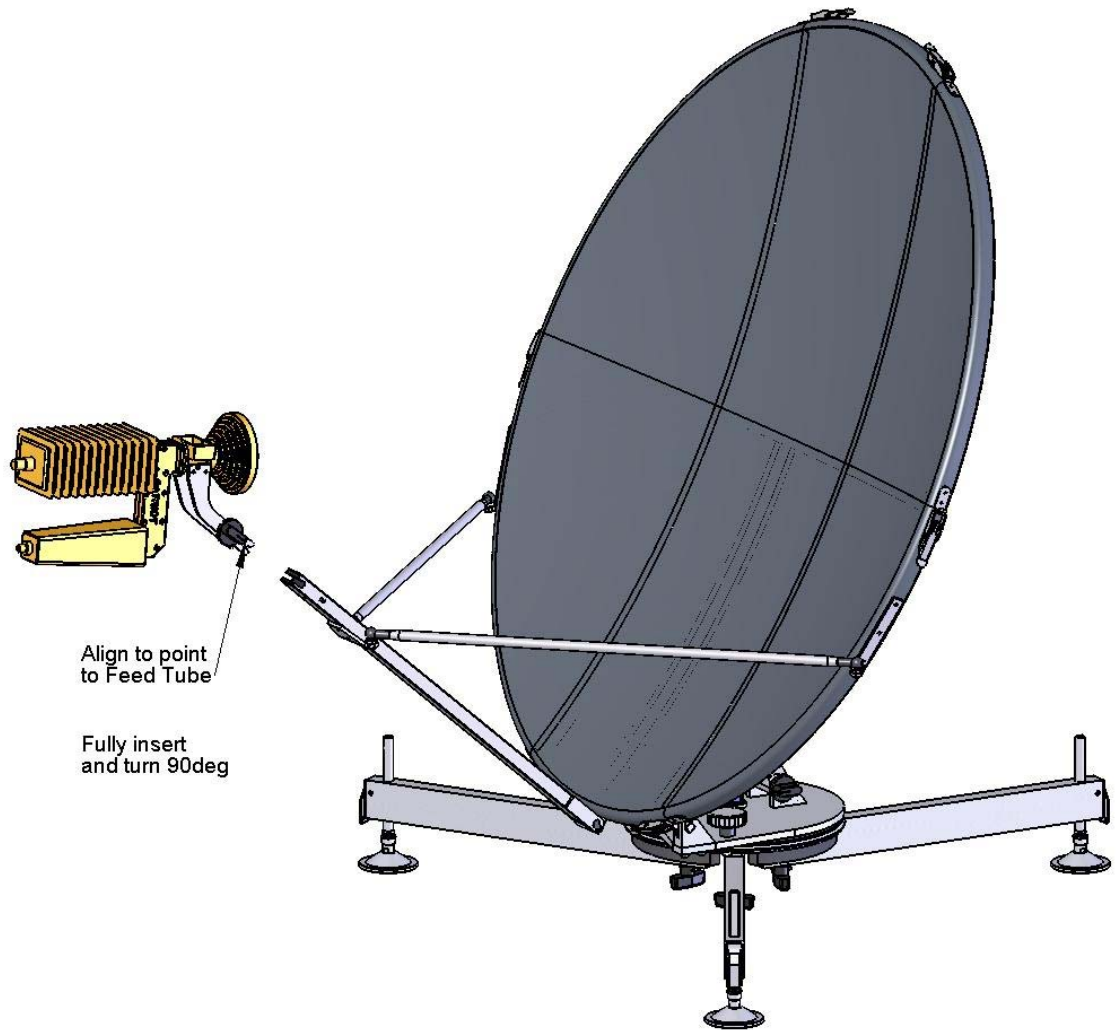

Assembly is now complete.

Antenna system can acquire satellite once RF connections are complete.